



### LPT4-19 Series Pull & Turn Slide-out Rack System - 19"D with 4-Slides

#### System Includes:

- Bottom Base with Turntable & 4 Heavy-duty Slides for 300lb load.
- Rack Base (removable)
- 6 Corner Post Rails (10-32) and 2 Side Stiffeners
- Cable Lacing Panels: 6 Qty.
- Front Security Panel: Perforated
- Powder Epoxy Finish: Smooth Black

#### Description

Lowell's LPT4-19 Series Pull and Turn mounting system for built-in wall and millwork applications features a turntable on four heavy-duty slides for smooth pullout access to rack mounted equipment. Load capacity is 300 lbs.

Sturdy and versatile system is engineered for efficient on-site installation. It is packaged unassembled in two cartons so that the bottom base (with slides and integral turntable) along with two rear corner post rails and three cable lacing bars can be sent ahead to the job site and installed in a boxed wall opening or cabinet. The second carton contains the rack base, front and rear posts, side stiffeners, front vent panel and three lacing bars to assemble the rack for pre-loading and testing of equipment in the shop - a real benefit for corporate boardroom and training facility installations.

The bottom base installs using (8) screws and may be mounted flush or recessed up to 2" into a boxed wall or cabinetry to allow for equipment protrusions (see page 2). The removable rack base, with or without mounted equipment, easily docks and secures to the bottom base using two screws on the front and rear frame (no wing nuts under the rack). When all equipment is in place and wired, the assembly is secured in fixed position with two screws through a perforated front security panel. To facilitate wiring and servicing of rack equipment, the security panel may be removed; allowing the rack to be pulled out smoothly from the wall or millwork on the heavy-duty slides. A convenient pushbutton lock and release, accessible in the center front of the bottom base, allows the rack to rotate 60° and 90° on the turntable. *Note the rack must be fully forward to rotate with adequate clearance. If it is recessed up to 2" it will not rotate the full 90°.* When servicing is complete, use the pushbutton to return the rack to its front-facing position, push it back into the wall and re-install the front security panel.

Components are manufactured from certified US steel and finished in smooth black powder epoxy. Choose models with panel space of 10, 12, 16 or 21RU. All provide 19" useable depth (19.22" overall). A 23" deep version is also available. See also LPT2 Series 19"D versions with 2-slides (150lb load).

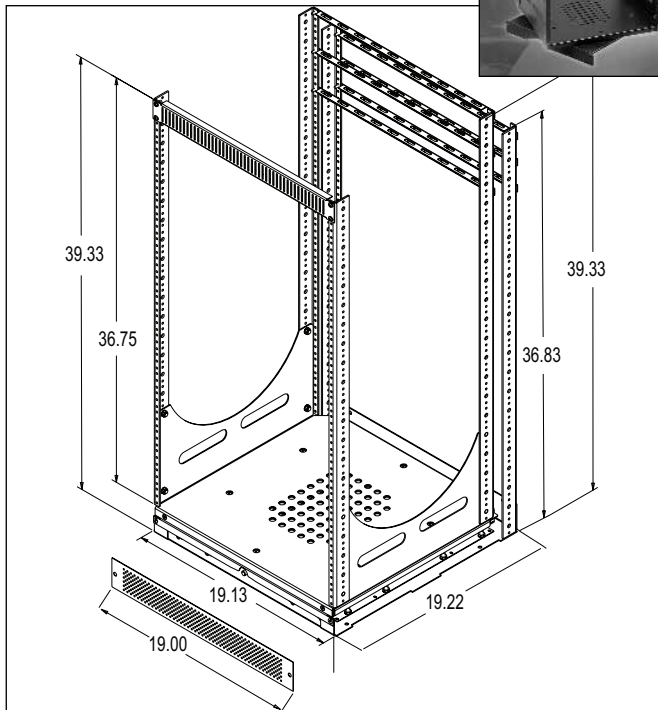
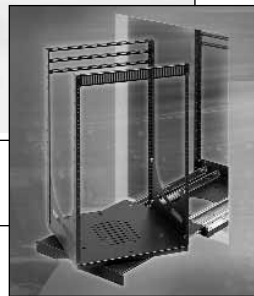

#### SPECIFICATIONS FOR LOWELL LPT4 SERIES 19"D PULL & TURN RACKS - 4 SLIDES

Model	Panel Space	Rack Units	Overall Height	Overall Width	Overall Depth	Useable Depth	Load Capacity	Cable Tie-off Panels
LPT4-1917	17.50"	10RU	20.08"	19.13"	19.22"	19.00"	300lbs.	6
LPT4-1921	21.00"	12RU	23.58"	19.13"	19.22"	19.00"	300lbs.	6
LPT4-1928	28.00"	16RU	30.58"	19.13"	19.22"	19.00"	300lbs.	6
LPT4-1936	36.75"	21RU	39.33"	19.13"	19.22"	19.00"	300lbs.	6



# LPT4-19 Series

## Slide-out (rotating) 19"W x 19"D Rack Frame System

# RACKS

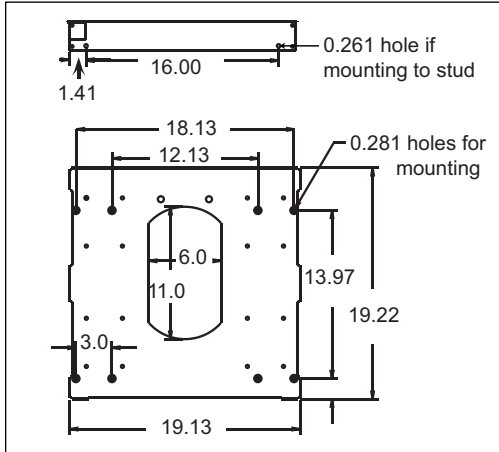

Bottom base installation

### A & E Specifications

The rack for built-in applications shall be Lowell LPT4-19 Series Model \_\_\_\_\_. It shall be 19.13"W and 19.22"D with 19" useable depth. Panel space shall be \_\_\_\_ (10RU, 12RU, 16RU, 21RU). The rack system shall include four heavy duty slides and a turntable base allowing it to pull out and rotate 60° and 90°. The rack shall be unassembled and ship in two cartons to facilitate job site installation of the bottom base and shop mounting and testing of the equipment. The rack system shall include cable management panels and be capable of supporting a 300lb load. It shall be manufactured from certified US steel and finished in smooth black powder epoxy.

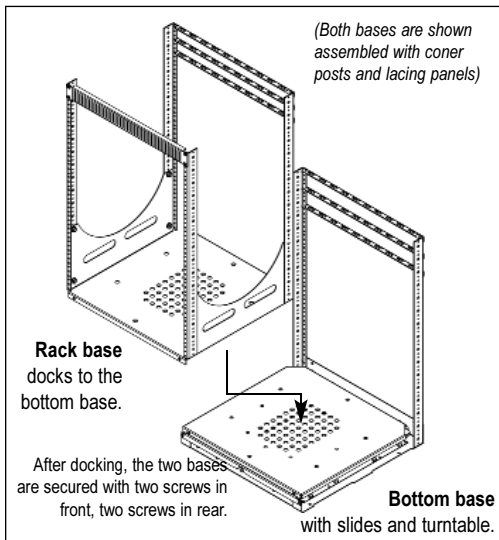

Bottom base with slides and turntable.

Docking and securing the rack base with or without mounted equipment to the bottom base with slides and turntable is easily accomplished using two screws on the front and rear frame (no wing nuts under the rack). When all equipment is in place and wired, the assembly is secured in fixed position with two screws through the front of the bottom base assembly.

Six lacing panels are provided to guide cabling.

**TIP:** Perform wire tie off when the rack is in the 90° maximum rotated position to ensure adequate slack.

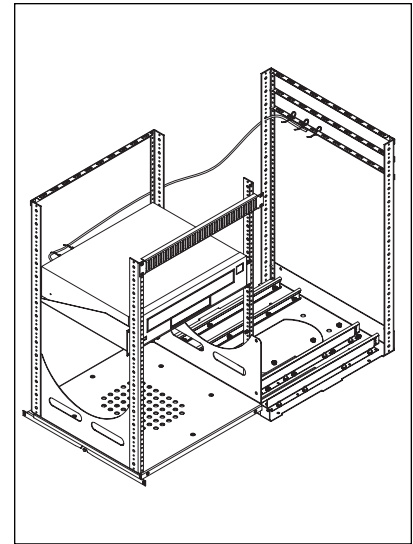

Shown in 90° position with cabling tied off.

Removable rack base allows shop wiring of equipment.

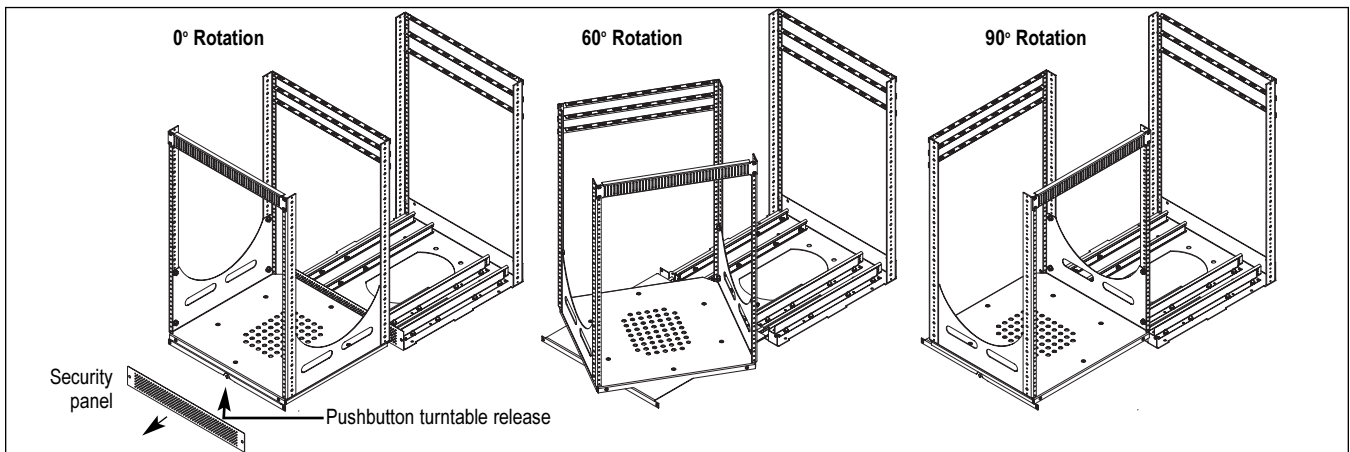

### To service an installed pull & turn rack system

- 1) Remove the bottom security panel (2 screws). *Note: if security panel is not used, the rack should be locked using two screws in the panel location.*
- 2) Pull the rack fully forward to clear the opening.
- 3) Locate the pushbutton in the center of the base.
- 4) Depress the pushbutton in the center of the base to release the turntable, allowing it to rotate to 60° right or left.
- 5) Depress the pushbutton again to rotate the rack to the 90° position. *Note: the 90° position is recommended when tying off cords and cables to rear lacing panels as it ensures adequate length at maximum turn radius.*

Open Frame Floor

Solid Side Floor & Desk

Wallmount Surface & Recessed

Panels & Accessories

Thermal & Wire Mngmt

Slide-out (rotating)