

PZM[®]-10

PZM-10LL

PRESSURE ZONE MICROPHONES



The Crown[®] PZM[®]-10 and PZM-10LL, part of the Pressure Zone Microphone[®] line, are designed for security, surveillance, and conference-table use. Since they do not look like microphones, they are inconspicuous. Each mic's tubular housing mounts in a 25/32-inch diameter hole in a ceiling panel, wall or table.

The PZM-10 has a mic-level output and a 3-pin XLR-type connector for easy plug-in installation. The mic requires 12 to 48V phantom power.

The PZM-10LL has a line-level output from its unterminated cable. It requires 12 to 24V DC.

Like other Pressure Zone Microphones, the PZM-10 and PZM-10LL use a miniature mic capsule mounted very near a sound-reflecting plate or boundary, in the Pressure Zone. In this zone, direct sound from the sound source combines in phase at all frequencies with reflected sound off the boundary. The benefits are many: 6 dB more sensitivity, 6 dB less noise, a wide smooth frequency response free of phase interference, excellent clarity and "reach," and consistent pickup anywhere around the mic.

Frequencies below the voice range are rolled off to reduce pickup of air conditioning rumble. The high-frequency response is boosted slightly to help articulation. Because of their tailored response and PZM construction, the PZM-10 and PZM-10LL will pick up conversations or other desired sounds with extra clarity and definition.

The output is balanced, low impedance, which allows long cable runs without hum pickup or high-frequency loss.

The mic's humbucking transformer and steel case prevent hum pickup, even near fluorescent lights.

Model PZM-10BLK has a black finish, and can be custom ordered from your Crown dealer.

Mic Placement

To pick up speech from a small conference table (about 6 feet square), mount the PZM-10 or PZM-10LL in the middle of the table. For longer tables, use one PZM in the middle of every 4 to 6 people. No person should be more than 3 feet from the nearest microphone.

(continued on back)

Features:

- Pressure Zone Microphones for security and surveillance
- Clear, intelligible pickup of speech
- Choice of mic level output (PZM-10) or line-level output (PZM-10LL)
- Inconspicuous, resembles a light switch
- PZM-10 powered by 12-48V phantom power
- PZM-10LL powered by 12-24V DC

Specifications

Transducer type: Electret condenser.

Frequency response (typical):

PZM-10: 80 Hz to 20,000 Hz. See Fig. 1. PZM-10LL: 100 Hz to 20,000 Hz. See Fig. 2.

Polar pattern: Hemispherical.

Impedance:

PZM-10: 240 ohms, balanced.
PZM-10LL: 75 ohms, balanced. Recommended minimum load impedance 1000 ohms.

Open circuit sensitivity:

PZM-10: 2.5 mV/Pa* (-52 dBV/Pa).
PZM-10LL: 1.4V/Pa* (+3 dBV/Pa).
See Table 1.

Power sensitivity:

PZM-10: -52 dBm/Pa*.
PZM-10LL: +8 dBm/Pa*.

Equivalent noise level (self-noise): 26 dB SPL typical (0 dB = .0002 dyne/cm²), A-weighted.

S/N Ratio: 68 dB at 94 dB SPL.

Maximum SPL: 120 dB SPL produces 3% THD.

Operating voltage:

PZM-10: 12 to 48V phantom power, positive voltage on pins 2 and 3 with respect to pin 1.
PZM-10LL: 12 to 24V DC, positive voltage on red lead with respect to shield.

Polarity:

PZM-10: Positive pressure on the diaphragm produces a positive voltage on pin 2 with respect to pin 3 of output connector.
PZM-10LL: Positive pressure on the diaphragm produces a positive voltage on white lead with respect to black lead.

Current drain:

PZM-10: 400 microamperes.
PZM-10LL: 2.8 mA at 12V DC, 4.22 mA at 24V DC. See Table 1.

Output connectors:

PZM-10: Male XLR type (3-pin pro audio). PZM-10LL: None.

Cable:

PZM-10: None supplied. Use 2-conductor shielded mic cable.
PZM-10LL: 12-in., permanently attached 3-conductor shielded cable. Red: B+, White: audio+, Black: audio-, Shield: ground.

Materials: Steel plate and housing.

Finish: Off-white. May be painted any color; take care to first seal the opening between the capsule and boundary plate. Model PZM-10BLK has a black finish, and can be custom ordered from your Crown dealer.

Net weight: PZM-10: 2.6 oz. (73.6 g).
PZM-10LL: 3.3 oz. (93.9 g).

Dimensions: See Fig. 3.

*1 pascal = 10 dynes/cm² = 10 microbars = 94 dB SPL.

Table 1

Effect of power-supply voltage on PZM-10LL sensitivity and current drain		
B+	SENSITIVITY	DRAIN
24V	1.4 V/Pa	4.22 mA
20V	1.4 V/Pa	3.00 mA
15V	1.0 V/Pa	2.75 mA
12V	0.9 V/Pa	2.50 mA



INSTALLED

PZM-10 PZM-10LL

Fig. 1

PZM-10 Frequency Response

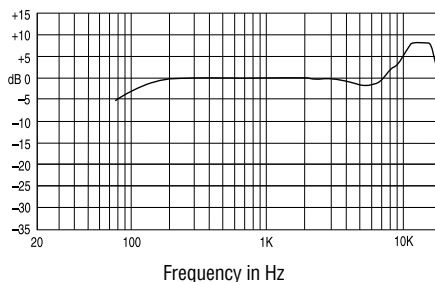
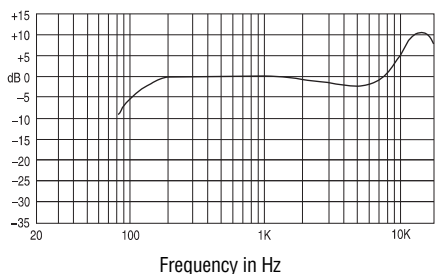

Fig. 2

PZM-10LL Frequency Response



Mic Placement (continued)

For other placement suggestions, see the *Crown Microphone Application Guide for Security and Surveillance* at www.crownaudio.com/mic_htm/mic_pubs.htm.

Mic Installation

1. Please refer to Fig. 3 and identify the parts shown.
2. Determine where you want to install the microphone, and drill a 25/32-inch diameter hole there.
3. **PZM-10 only:** Obtain some 2-conductor shielded mic cable, long enough to run from your equipment input to the microphone. If space is tight behind the mounting surface, obtain a right-angle female XLR connector. Solder the female XLR connector onto the cable: shield to pin 1, hot lead to pin 2, other lead to pin 3.
- PZM-10LL only:** Obtain enough mic cable to run from your equipment input to the microphone. You can use either a 2-conductor shielded mic cable with a separate DC power lead, or a 3-conductor shielded mic cable (with one of the leads used for power).
4. Run the female XLR (if used) and mic cable to the hole.
5. Using a 5/32-in. Allen wrench, remove the collar from the microphone. Insert the microphone tube into the hole.

6. Slide the collar onto the mic tube. Pull the plate tight against the hole and press the collar tight against the mounting surface. Tighten the Allen screw in the collar.

7. **PZM-10 only:** Plug your mic cable into the microphone.

PZM-10LL only: Solder the PZM-10LL cable leads to your mic cable as described below:

- Red to 12-24V DC
- White to Audio + lead
- Black to Audio - lead
- Shield to cable shield and power supply -.

8. **PZM-10 only:** Plug the other end of your mic cable into one of these devices:

- * A mic preamp that supplies phantom power.
- * A mixer that supplies phantom power.
- * A phantom power supply, such as the Crown PH-4B or PH-1A.

Connect the output of the supply to the mic input of your mic preamp, mixer or recorder.

Architects' and Engineers' Specifications

PZM-10

The microphone shall be the Crown PZM-10 or equivalent. The microphone shall be an electret condenser Pressure Zone Microphone with a hemispherical polar pattern. The microphone shall have a tubular housing which mounts in a 25/32-in. diameter hole. Open-circuit sensitivity shall be 2.5 mV/Pa typical. Equivalent noise level shall be 26 dBA typical. Maximum SPL shall be 120 dB for 3% THD. Powering shall be 12-48 V phantom power. Output connector shall be male XLR-type. The Crown PZM-10 microphone is specified.

Architects' and Engineers' Specifications

PZM-10LL

The microphone shall be the Crown PZM-10LL or equivalent. The microphone shall be an electret condenser Pressure Zone Microphone with a hemispherical polar pattern. The microphone shall have a tubular housing which mounts in a 25/32-in. diameter hole. Open-circuit sensitivity shall be 1.4V/Pa typical. Equivalent noise level shall be 26 dBA typical. Maximum SPL shall be 120 dB for 3% THD. Powering shall be 12-24 V DC. The microphone shall have a 12-in. unterminated cable. The Crown PZM-10LL microphone is specified.

Warranty

Crown professional microphones are guaranteed against malfunction for a period of three years from date of original purchase. Please refer to the enclosed full warranty statement for more detail.

Service

If the unit fails to work, first replace or repair the mic cables and check the power supply. A Service Return Authorization (SRA) is required for product being sent to the factory for service. An SRA can be completed on line at www.crownaudio.com/support/factserv.htm. If service is required, return the microphone in its original packaging to: **Crown Factory Service, 1718 West Mishawaka Road, Elkhart, Indiana 46517-9439**. For further assistance or technical support call **800-342-6939**.

Fig. 3 Dimensions

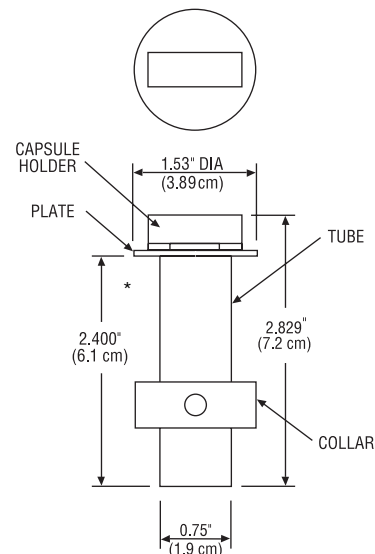

*2.450 in. (6.2 cm) in PZM-10LL



H A Harman International Company

Crown International, Inc.
1718 W. Mishawaka Rd.
Elkhart, IN 46517-9439
TEL: 574-294-8000
FAX: 574-294-8FAX
www.crownaudio.com

©2005 Crown Audio®, Inc. Specifications subject to change without prior notice. Latest information available at www.crownaudio.com. Crown, Crown Audio, PZM and Pressure Zone Microphone are registered trademarks of Crown International. Pressure Recording Process is a trademark of E.M. Long Associates.