

# OM2 DYNAMIC VOCAL MICROPHONE

## overview

The OM2 is an American-made, hand held vocal microphone designed primarily for live performance. Characterized with a hypercardioid pickup pattern and a frequency response of 50-16k Hz, the OM2 has the same well-balanced, comfortable profile as Audix's high-end touring vocal mics, featuring a low reflective black e-coat finish.

Transformerless design, low impedance, and balanced output allow interference-free performance even with long cable runs. A dent-resistant spring-steel grill and sound pressure handling capabilities in excess of 140dB add to the OM2's road-worthiness.

The OM2 is available with on-off switch (model OM2-S).

## specifications

Transducer Type	Dynamic
Frequency Response	50 Hz- 16kHz
Polar Pattern	Hypercardioid
Output Impedance	250 ohms
Sensitivity	71.5dB
Capsule Technology	VLM Type B
Off axis rejection	>25dB
Maximum SPL	>140dB
Cable/Connector	3 pin gold plated male XLR
Polarity	Positive voltage on pin 2 relative to pin 3 of output XLR connector
Housing	Zinc alloy
Weight	10.5oz/298 grams

## OM2 DYNAMIC MIC



Vocals



Congas



Drums



Electric Guitar

## applications

- ▶ **Live Stage**  
*Coffeeshouse, small to medium club, Praise-team and gospel vocal groups, outdoor festivals*
- ▶ **Utility instruments**  
*Electric guitar, snare, tom-tom, congas*
- ▶ **Spoken Word**
- ▶ **Home Studio**  
*Vocal and instrument applications*

# OM2 DYNAMIC VOCAL MICROPHONE

**Operation and Maintenance:** The OM-2 is a durable handheld dynamic microphone with a dent-resistant spring steel grill. It still should be handled with care. Avoid extreme temperatures wherever possible. Moisture can adversely affect the sound and performance of your microphone. For outdoor use, consider using the optional external windscreen (WS-357) to reduce wind noise. When not in use please store in provided pouch.

**Recording:** The OM-2 is a very versatile recording microphone. It is a cost-effective utility microphone for use with vocals, percussion, electric and acoustic guitar, and brass instruments. Because of the hypercardioid pattern, it is important to align the OM-2 on axis with the sound source. Its high sound pressure handling will prevent diaphragm distortion, allowing for close miking of the instrument or voice.

**Live Sound:** The OM2's tight pattern and high off-axis rejection offer unmatched gain before feedback providing a full-bodied warmth that complements lower-profile floor monitors found in smaller performance venues. The high rejection also allows for multiple miking in tight quarters (i.e. small clubs) with little bleed through or feedback. The OM2 has added warmth in the lower mid-bass and a slight boost in the mid-range; it sounds particularly full and clear on small-to-mid size PA systems without having to add EQ or pad the sensitivity. Microphone placement is not an exact science and depends on the room size, the PA system, and the musicians. Therefore, some experimentation is usually necessary in order to achieve the desired results.

In general, when using multiple OM2 mics for live sound, they should be spaced 2-3 feet apart.

## Supplied Accessories

- ▶ Mic clip (MC1) adjustable through 180 degrees with standard 5/8 inch 27 thread. Note: Metal stand adapter also supplied to accommodate European standard threads.
- ▶ Zippered microphone carrying pouch.

## Typical Frequency Response

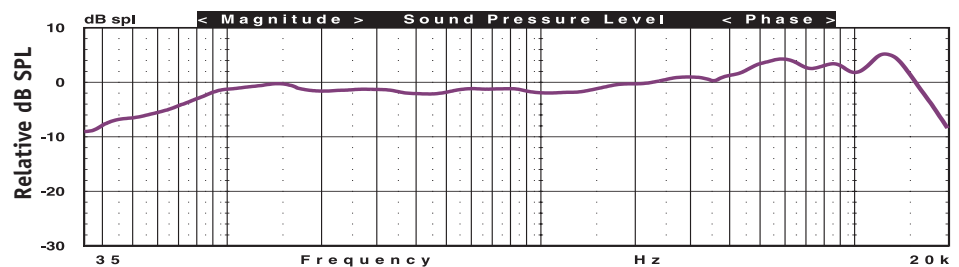

## Polar Charts

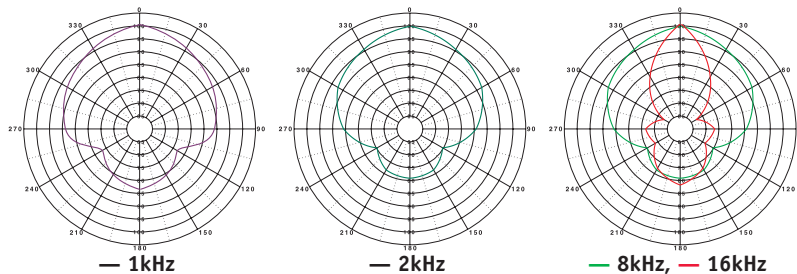

The frequency response curve shown above (measuring tolerance at  $\pm 3\text{dB}$ ) and polar pattern correspond to typical production run specifications for this microphone.

## Measurements

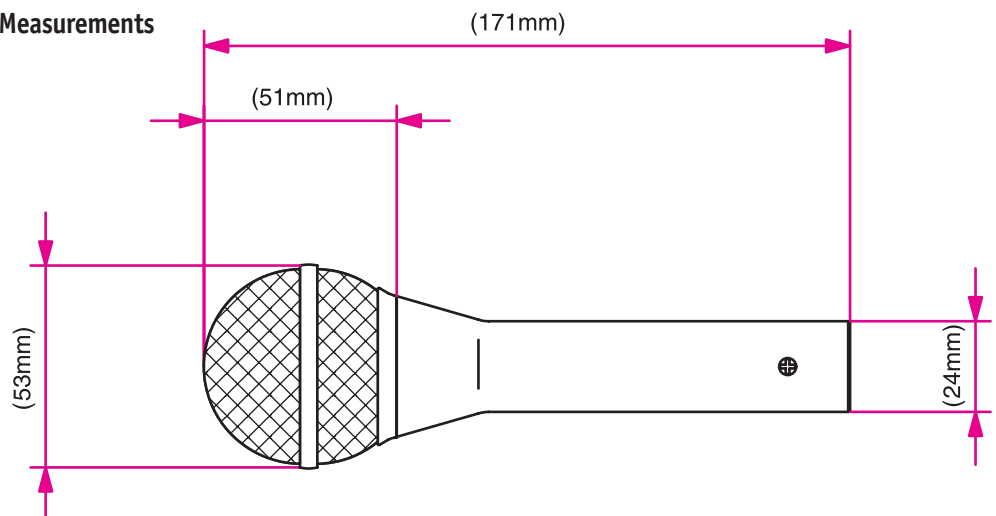

CALL: 503-682-6933 FAX: 503-682-7114  
www.audixusa.com

Audix Corporation PO Box 4010, Wilsonville, OR 97070 In Canada, Cabletek Electronics LTD, 604-942-1001 fax 604-942-1010  
© Audix Corporation 2000. All rights reserved. Audix and the Audix logo are trademarks of Audix Corporation.

**AUDIX**  
PERFORMANCE IS EVERYTHING