



[en](#)
[jp](#)
[cn](#)

 DP-32SD

- [PRODUCTS](#) ||
 [RECORDING](#) |
 [MUSICIAN](#) |
 [BROADCAST](#) |
 [CONTRACTOR](#) |
 [SUPPORT](#) |
 [CONTACT](#) |
 [WHERE TO BUY](#) |
 [STORE](#) |
 [ARTISTS](#) |
 [NEWS](#)

Products :: Digital Portastudio :: DP-32SD

Related Products



DP-32SD
32-TRACK DIGITAL PORTASTUDIO

32-TRACK DIGITAL PORTASTUDIO
DP-32



MTR DIGITAL PORTASTUDIO

16 X 4 USB AUDIO INTERFACE
US-1800



PC AUDIO INTERFACE

- [OVERVIEW](#) |
 [IMAGES](#) |
 [SPECIFICATIONS](#) |
 [DOWNLOADS](#)

Products in this Category

DP-32SD OVERVIEW

- DP-24SD**
24-Track Digital Portastudio
- DP-03SD**
8-Track Digital Portastudio
- DP-008EX**
8-track Digital Pocketstudio
- DP-006**
6-track Digital Pocketstudio

TASCAM's DP-32SD Digital Portastudio records an unmatched 32 tracks to solid-state media. Up to eight tracks can be recorded at a time through its combination XLR and 1/4" combo jacks. Input processing like compression and limiting are available during recording, as well as guitar amp simulation and multi-effects for use with the instrument-level input. A color LCD and channel strip knobs make mixing fast and creative. The included 4GB SD card can be replaced with up to 32GB SCHC media or swapped with other cards between projects. With its great sound, powerful features and easy operation, the DP-32SD is TASCAM's biggest Portastudio yet.

Main Features

Dedicated Recording features	The DP-32SD provides a creative musical experience	Built-in Project Mastering and Finalizing	High-quality, dependable hardware design	Features at-a-glance
------------------------------	--	---	--	----------------------

Dedicated DP-32 Recording Features [To TOP](#)

Twelve Mono and Twelve Stereo Tracks

The DP-32 has 12 selectable tracks between MONO or STEREO. Use a STEREO track for recording synthesizer, or set the track to MONO when recording guitar or vocal. Not only that, you can create ideal settings for each track. (set #9 to #12 STEREO, then set #13 to #22 MONO) If all tracks are set to MONO the DP-32 becomes a 20-track multi track recorder.



The DP-32SD provides a creative musical experience [To TOP](#)

21 faders eliminates layer structuring

The DP-32, even with the high number of tracks, is one of the easiest multi-track recorders in the market to use. The DP-32SD has 20 track-faders and one master fader. You can control any track with ease.

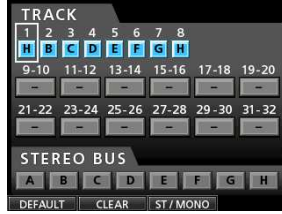

The 3.5" full-color LCD and the self-illuminated buttons increase visibility

The DP-32SD has a 3.5" LCD screen and select self-illuminated buttons, making it easy to view your entire creative process. Some of the illuminated buttons include (SOURCE, SELECT, REC, MUTE).



12 rotary knobs linked to the LCD to help increase easy operation



The DP-24/32 have similarly employed rotary knobs to control qualities such as EQ, Effect Send and other related features.

Utilizing SD/SDHC media ensures confident recording, free from shock due to loud sounds



The DP-32SD uses SD/SDHC media. These cards provide secure shock resistance due to the absence of any moving parts. The file format in the DP-32SD is FAT 16 or 32. You can transfer the recorded files to your computer via USB.

8 XLR/TRS inputs, 8 channel recording, 32 tracks playback

The DP-32SD has 8 XLR-TRS combo inputs. You can record up to eight sources at one time.

INPUT A-H and each track are equipped with 3-band EQ



The equalizer for each track and each input are independent from other effects. Record like any professional studio with EQ for each individual track.

8 dynamics effects, guitar effects and mix-down effects

Use up to 8 dynamics effects at once, one for each input source. For example, utilize the built-in compressor effect for your bass, guitar and drums tracks. In addition, the DP-32SD have multiple guitar and mixing effects.

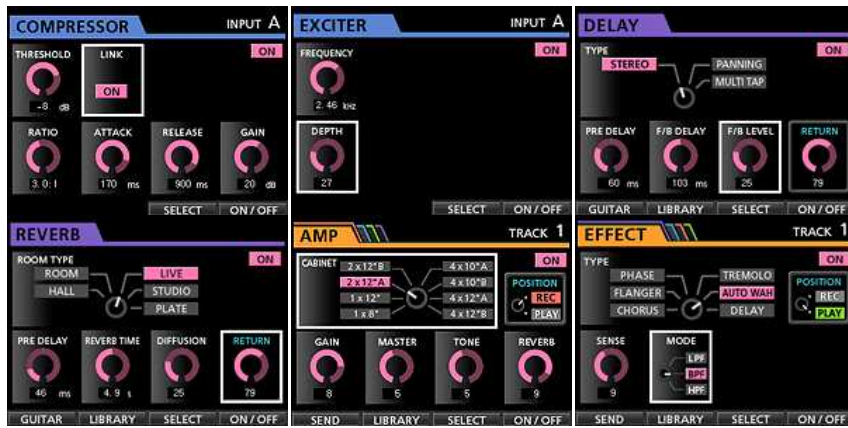

Built-in Digital Mastering



The DP-32SD is equipped with mastering effects for finished-sounding mixes. There is no need for computers when recording and mixing. The mastering effects section includes a Multi-Band Compressor, EQ, Noise-Shaping Dither, and a Normalize Effects. You can create a high-quality 2-track master file for transfer to your computer to burn a CD or share online.

High-quality, Dependable Hardware

[To TOP](#)

The headphone amplifier has a high output power of 70mW/ch



The headphone amplifier provides easy monitoring in loud environments such as a rehearsal studios or live performance.

RCA stereo output and two unbalanced 1/4" TS outputs



High-impedance input available on INPUT H when set to GUITAR



Phantom power supply for all inputs



Dedicated TRS balanced MONITOR OUT for the powered speakers

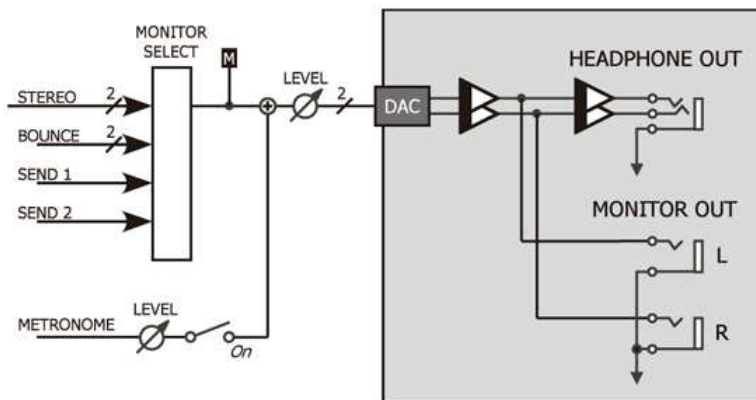

Remote connector for optional RC-3F footswitch



Function	Description
PLAY	Same as unit's PLAY button
REC	Same as unit's RECORD button
STOP	Same as unit's STOP button
FF	Same as unit's F FWD(TO LAST REC) button
REW	Same as unit's REW(TO ZERO) button
PUNCH IN / OUT	Punches in when pressed during playback, punches out when pressed during recording.
PLAY/STOP	Starts playback when stopped, stops in other states.
CUE LOCATE	Locates last point where playback started.

Features at-a-glance

[To TOP](#)

- Simultaneous 32 track playback
- 8 mono tracks + 12 mono/stereo selectable tracks
- Mounted TMSS (TASCAM Multi Stage Sampling rate converter) provides high-quality sampling rate conversion
- Integrated 40-input mixer to mixdown the 32 playback tracks with the 8 inputs or for bouncing
- Simultaneous 8 track recording
- 16 or 24 bit, 44.1 or 48 kHz recording
- 8 XLR/TRS combo connectors
- Phantom power supply for all inputs
- High-impedance input available (INPUT-H)
- Stereo RCA pin-jack output
- 2 effect send outputs (1/4" TS jack)
- 70mW/ch headphone amplifier
- Peak-hold function at a level meter of the LCD
- Sub-frame editing
- Remote connector for optional RC-3F footswitch
- INPUT A-H and each track are equipped with 3-band EQ
- Automatic punch in/out
- Various edit functions (COPY INSERT, COPY PASTE, MOVE INSERT, MOVE PASTE, OPEN, CUT, SILENCE, CLONE TRACK, CLEAN OUT)
- Undo and Redo function with Undo history
- 8 dynamics effects
- Guitar effects
- Mix-down effects
- Mastering Effects
- Track bounce function
- Virtual tracks (8 virtual track per one track)
- Locate mark up to 99 at one song
- File transferring via USB2.0
- Chromatic tuner
- Metronome
- Dedicated AC adapter included (TASCAM PS-1225L)
- 8 mono and 12 mono/stereo selectable tracks
- 21 faders (19 track-faders and one master fader)



Options

TASCAM
[RC-3F](#)



Foot Switch

TASCAM Home	Products	Support	Contact	News	Where to Buy	Sitemap
TEAC Corporate	Recording Musician Broadcast Contractor Legacy	Product Registration Downloads FAQs Warranty Information	Pre-Sales Information Operational Support Repair Parts Legal	What's New Press Releases Events Artist News Artist Profiles	Store	About TASCAM Job Opportunities Corporate Identity Global Terms of Use Privacy Policy Trademarks

Follow us: [f](#) on Facebook [t](#) on Twitter [You Tube](#) on YouTube [✉](#) Join Email List

TASCAM is a trademark of TEAC Corporation, registered in the U.S. and other countries.
Other company names, product names and logos are the trademarks or registered trademarks of their respective owners.

Copyright © 2016 TASCAM, a division of TEAC America, Inc. All Rights Reserved.

