

Products :: Digital Portastudio :: DP-24SD

Related Products



DIGITAL PORTASTUDIO III DP-24SD

POWERED REFERENCE MONITOR
VL-S5



STUDIO MONITORS

24bit/96kHz | Wi-Fi | 4ch
Portable Handheld Recorder with Wi-Fi
DR-44WL



- OVERVIEW
- IMAGES
- SPECIFICATIONS
- DOWNLOADS
- BUY NOW

Products in this Category

DP-24SD OVERVIEW

The TASCAM DP-24SD – A Complete Digital Studio

The DP-24SD Digital Portastudio is a 24-track workstation, allowing eight tracks of simultaneous recording. The built-in mixer includes everything you need for a professional-sounding mix, from EQ and reverb to amp simulation and multi-band mastering effects. The Digital Portastudio series creates finished productions without the need for a computer, instead using a simple-to-use control surface to keep you creative.

For clear display of your mix, the DP-24SD has a large, full color LCD displaying tracks, meters, and effects parameters. A set of 12 encoders control EQ, effects sends, and panning. Built-in effects include compression, guitar amp modeling, delay, reverb, with a total of 10 effects processors available during mixing.

Eight XLR mic/line inputs each provide phantom power for condenser microphones, switchable in banks of four. One input includes an instrument-level impedance switch for direct input recording of guitar or bass. Balanced monitor outputs and effects sends are also provided on the rear panel. A USB output allows tracks and mixes recorded to your SD card to be transferred to a computer for CD burning or sharing online.

For complete music production on a desktop, there's no simpler choice than the DP-24SD.

- DP-32SD
32-Track Digital Portastudio
- DP-03SD
8-Track Digital Portastudio
- DP-008EX
8-track Digital Pocketstudio
- DP-006
6-track Digital Pocketstudio

Lineup



DP-03SD



DP-24SD



DP-32SD

Main Features

Stress-free user interface for easy recording	Project Mastering and Finalizing without the need for other devices	Professional connections integrate with your studio hardware	Features at a glance
---	---	--	----------------------

Stress-free user interface for easy recording

[To Top](#)

19 faders eliminates layer structuring

Even with the DP-24SD's number of tracks and features, there's no easier multi-track recorder to use. Eighteen track faders and one master fader allows instant access to any track without selecting pages or banks of faders.



A 3.5" full-color LCD and self-illuminated buttons for increased visibility

Both models have a 3.5" LCD screen and select, self-illuminated buttons - making it easy to view your entire creative process. Some of the illuminated buttons include (SOURCE, SELECT, REC, MUTE).



12 rotary knobs are linked to the LCD for easy operation



The DP-24SD have similarly employed rotary knobs to control dynamics such as EQ, effect send and other related features.

Solid-state SD/SDHC media ensures confident recording, free from shock and vibration



The DP-24SD employ SD/SDHC media. SD/SDHC cards provide secure shock resistance due to the absence of any moving parts. File format of the DP-24SD is FAT 16 or 32. The Portastudio recorded files can be accessed on your computer when connected via USB.

Project Mastering and Finalizing without the need for other devices

[To Top](#)

8 XLR/TRS inputs, 8 channel recording, 24 track playback

Both units have 8 XLR-TRS combo inputs. You can record up to eight sources at one time.

INPUT A-H and each track are equipped with 3-band EQ



The equalizer for each track and each input are independent from other effects. Record like any professional studio with EQ for each individual track.

8 dynamics effects, guitar effects and mix-down effects

Use up to 8 dynamics effects at once, one for each input source. For example, utilize the built-in compressor effect for your bass, guitar and drum tracks. A multieffects processor includes guitar amp modeling, chorus, flange, delay and other effects.

When the multieffects processor is used, only four dynamics effects are available. The stereo reverb on send/return 1 is always available.



Mastering effects provided without the need for other devices



Create a master track without using a computer with the TASCAM mastering effects. In the mastering effect section you will find a 3-band equalizer, a 3-band multiband compressor and 3 normalize effects for setting peak amplitude - take your stereo master file to the next level of quality.

Professional Connections Integrate with your Studio Hardware

[To Top](#)

The headphone amplifier has a high output power of 70mW/ch



The headphone amplifier of the DP-24SD provide easy monitoring in loud environments such as a rehearsal studio or live event.

RCA stereo output and two unbalanced 1/4" TS outputs



High-impedance input available on INPUT H when set to GUITAR



Phantom power supplied on all inputs



Dedicated MONITOR OUT for monitor speakers

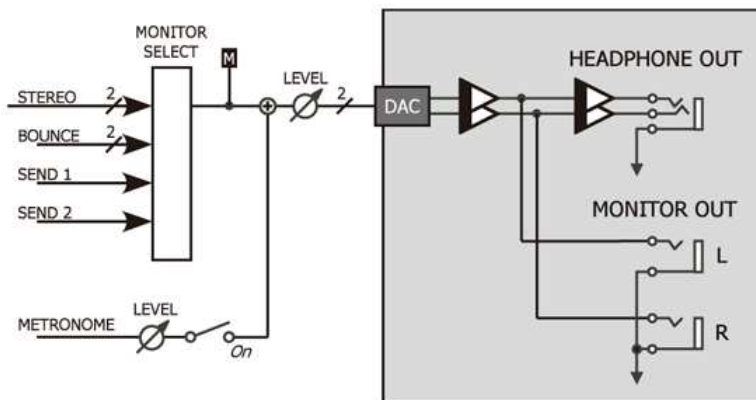

Remote connector for optional RC-3F footswitch



Features at a glance

[To Top](#)

- Simultaneous 24-track playback
- 12 mono tracks + 6 stereo tracks
- Simultaneous 8-track recording
- 16 or 24 bit, 44.1 or 48 kHz recording
- 8 XLR/TRS combo connectors
- Phantom power supplied on all inputs (INPUT A-D,E-H)
- High-impedance input available (INPUT H)
- Stereo RCA output
- 2 effect send outputs (1/4" TS jack)
- 70mW/ch headphone amplifier
- Remote connector for optional RC-3F footswitch
- INPUT A-H and each track equipped with 3-band EQ
- Automatic punch in/out
- Various edit functions (COPY INSERT, COPY PASTE, MOVE INSERT, MOVE PASTE, OPEN, CUT, SILENCE, CLONE TRACK, CLEAN OUT)
- Undo and Redo function with Undo history
- Dynamics effects for input (Limiter, Compressor, Noise Suppressor, Exciter)
- Guitar effects (Amp Simulator, Reverb, Compressor, Chorus, Flanger, Phaser)
- Mix-down effects (Reverb, Delay, Stereo Chorus)
- Mastering Effects (Multi-band Compressor, Equalizer, Dither, Normalize)
- Track bounce function
- Virtual track (8 virtual track per one track: including use track)
- Locate mark up to 99 for one song
- File transferring via USB2.0
- Chromatic tuner
- Metronome
- 19 Faders
- Peak-hold function on the level meter of the LCD
- Sub-frame editing
- Dedicated AC adapter included (TASCAM GPE248-120200-Z)
- SD card included
- RoHS certified

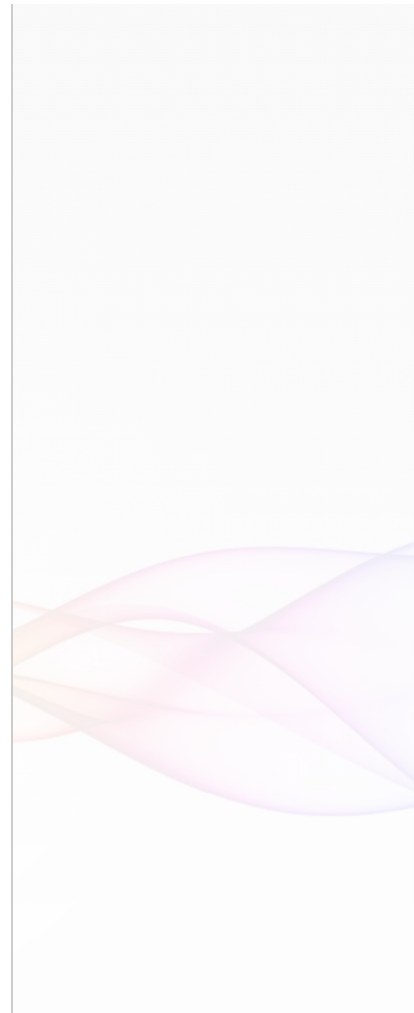

TASCAM Home	Products	Support	Contact	News	Where to Buy	Sitemap
TEAC Corporate	Recording Musician Broadcast Contractor Legacy	Product Registration Downloads FAQs Warranty Information	Pre-Sales Information Operational Support Repair Parts Legal	What's New Press Releases Events Artist News Artist Profiles	Store	About TASCAM Job Opportunities Corporate Identity Global Terms of Use Privacy Policy Trademarks

Follow us: [f](#) on Facebook [t](#) on Twitter [You Tube](#) on YouTube [✉](#) Join Email List

TASCAM is a trademark of TEAC Corporation, registered in the U.S. and other countries.
Other company names, product names and logos are the trademarks or registered trademarks of their respective owners.

Copyright © 2016 TASCAM, a division of TEAC America, Inc. All Rights Reserved.