



# PM3/M Pole Mount Bracket Installation Guide

January 2015

The One Systems PM3/M pole mount system is an easy to install and flexible system designed to allow specific ONE SYSTEMS loudspeaker products to be mounted to pole structures. The only products approved for use with the PM3/M are as follows: 108/HTC, 108/HTH, and 208/HTC.

## **NO OTHER LOUDSPEAKERS SHOULD BE SUBSTITUTED!**

The following actions **MUST** be performed **PRIOR** to beginning the installation of the PM3/M:

1. This installation guide must be completely read and understood.
2. The instruction manual “Rigging and Suspension of ONE SYSTEMS Products” must be read and understood. (This instruction manual is available along with other technical papers at [www.onesystems.com](http://www.onesystems.com) under the “Documentation” tab).
3. The structure of the mating surface **MUST** be capable of supporting the combined weight of the pan and tilt bracket, the loudspeaker and all associated rigging; and must satisfy the required safety factors specified by local and national codes, as well as safe rigging practices. The PM3/M weighs 4.16kg (9.2 lbs).
4. The PM3/M pan and tilt bracket should be installed only by someone experienced in the overhead suspension of items. They should be familiar with applicable local/national codes governing the installation of these types of products and those governing the attachment of these types of products to specific pole structures.
5. **The PM3/M is available in 316 (Marine) grade stainless steel only.**

**NOTE:** Caution should be exercised when connecting One Systems Marine grade products and Marine grade rigging to other metallic, non 316 grade stainless steel surfaces (dissimilar metals). The potential for galvanic corrosion is high in marine environments, where the One Systems Marine grade enclosures and rigging are specified or required. Compatible metals and appropriate anode to cathode area ratios must be maintained. A structural engineer with galvanic corrosion experience should be consulted prior to installation of ANY One Systems products in marine environments.

**CAUTION:** All structures outdoors are subjected to wind forces. These forces must be considered when suspending any product outdoors. It is necessary to know the “Effective Projected Area” (EPA) of the loudspeaker prior to installation of the loudspeaker and the PM3/M. See Appendix 1 of this installation manual for effective projected areas for each enclosure rated for use with the PM3/M. Periodic inspections of the rigging, loudspeaker enclosure and installation are strongly recommended.

**IMPORTANT NOTE:** All products in direct weather installations can be subjected to high wind speeds. For wind speed exposure over 74 miles per hour (119.1 kilometers per hour, 64.3 knots) the loudspeaker enclosure, bracket, banding, and link assembly or safety must be inspected for signs of damage or fatigue!

## INSTALLATION

### PM3/M Installation

The PM3/M may be used on round or square poles.

For square/rectangular poles the minimum flat dimension must be 3.75 inches (95.25mm) at mounting height and for round poles the minimum required diameter is 4 inches (101.6mm) at mounting height.

The PM3-M was designed for use with the 108/HTC, 108/HTH and the 208/HTC only. NO SUBSTITUTIONS ARE ALLOWED!

**NOTE:** One Systems does not imply suitability of specific pole diameters. Each pole must be verified by the pole manufacturer or others, as to the structural suitability of the pole for use with the total load of the PM3/M, the loudspeaker, and all required safety factors.

**THE PM3/M is designed for pole mounting ONLY! DO NOT wall mount the PM3/M!**

The PM3/M is shown below. The PM3/M allows a down tilt of 40 degrees in 8 degree increments.

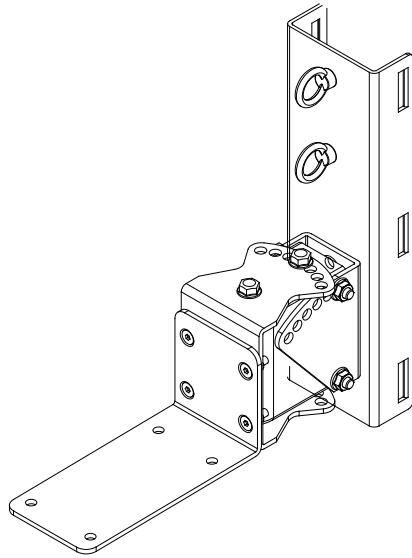

### PM3/M

The PM3/M consists of three parts: the pole bracket, the loudspeaker bracket, and the Link. The PM3/M pole bracket is shown below.

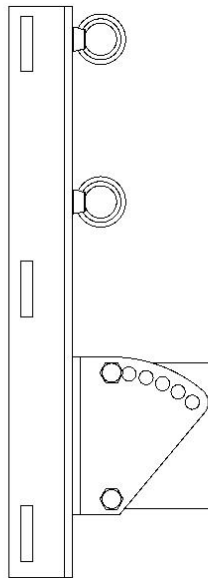

PM3/M pole bracket

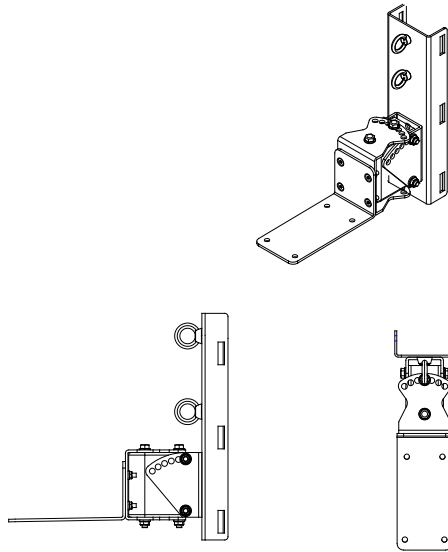

Views of the PM3/M

Prior to mounting the pole bracket to the pole, the speaker mount section should be removed. To remove the speaker mount section remove the pan pivot bolt and pan aiming bolt. See the figure below and refer to page 10 for the location of the pan pivot bolt and pan aiming bolt.

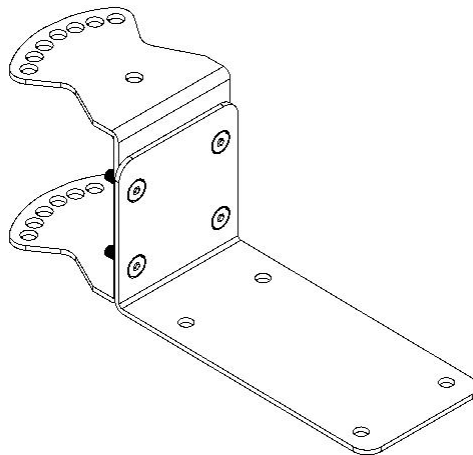

Speaker mount section

**NOTE:** There are three M8 forged shoulder eyebolts supplied with the PM3/M. Make sure that two of them are mounted to the PM3/M back plate (pole bracket) as shown on page 3 BEFORE attempting to mount the PM3/M pole bracket assembly to a pole structure!

**NOTE:** Instructions for mounting the Band-It bands and buckles are supplied by Band-It.

The PM3/M has three slots for mounting the pole bracket assembly on a pole. ALL THREE slots MUST be used. Each slot MUST be DOUBLE WRAPPED (two INDEPENDENT bands per slot!) using the specified Band-It straps ONLY! DO NOT substitute any other straps. IT IS NECESSARY TO USE ALL MOUNTING SLOTS TO INSURE A SAFE AND SECURE MATE TO THE ASSOCIATED SURFACE!

**IMPORTANT:** It is REQUIRED that each of the three band slots be wrapped TWICE (TWO INDEPENDENT SINGLE WRAPS PER SLOT). This should not be confused with “double wrapping”, which is two wraps of the band thru a single buckle. This means that a total of 6 bands and 6 buckles are required for a single PM3/M bracket. Two independent single wraps per slot will insure a strong and secure mounting of the bracket to the pole. Insure that the two buckles are separated from each other in each slot! The image below illustrates the double wrapping required for each of the three slots.

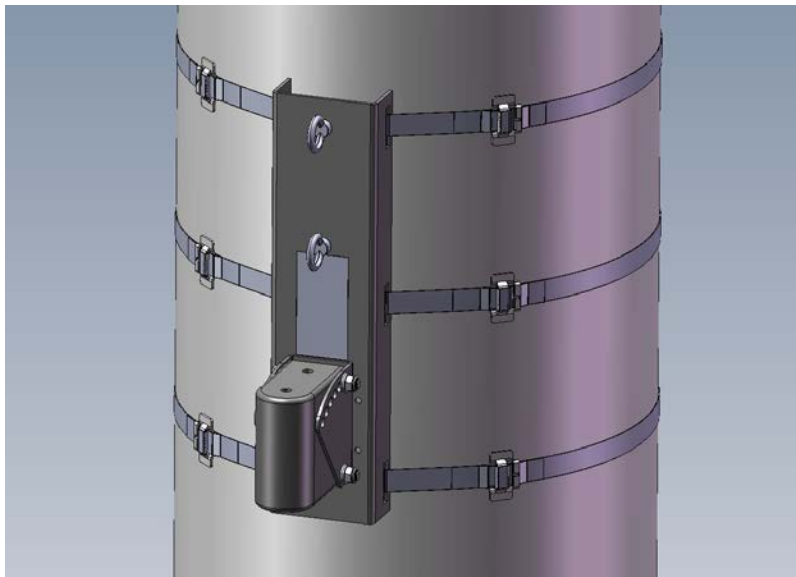

Note the TWO independent bands and buckles per slot

IT IS CRITICAL THAT THE MATING SURFACE (Pole) BE CAPABLE OF SUPPORTING THE LOAD OF THE PM3/M BRACKET, THE LOUDSPEAKER AND ALL SUSPENSION HARDWARE, AS WELL AS PROVIDING THE PROPER SAFETY FACTORS. DO NOT ATTEMPT TO SUSPEND THE BRACKET AND LOUDSPEAKER UNTIL THE STRUCTURAL CHARACTERISTICS OF THE MATING SURFACE (Pole) ARE UNDERSTOOD. DO NOT INSTALL THE POLE MOUNT BRACKET AND

LOUDSPEAKER IF THE MATING SURFACE (Pole) IS NOT CAPABLE OF SUPPORTING THE ENTIRE ASSEMBLY WEIGHT, AS WELL AS PROVIDING THE REQUIRED SAFETY FACTORS!

**IMPORTANT:** There are 3 slots indicated by the red arrows in the image below. Each of the 3 slots must be utilized to insure a secure mount to a pole. ALL 3 slots must use double wrapped bands (Two independent bands wrapped in each slot)! The image below shows the PM3/M mounted to a round pole. As shown, ALL three band slots must be used and all locations MUST be double wrapped (two independent band assemblies per slot per the image on page 5 of this manual!)

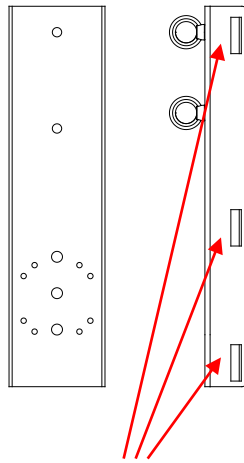

The red arrows indicate the 3 slots used to band the PM3/M to a pole structure

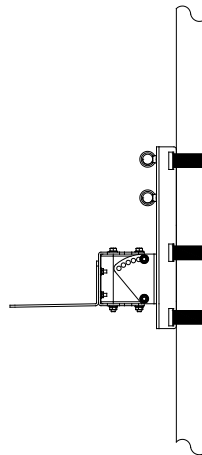

The PM3/M showing ALL three band locations used

Mount the PM3/M bracket assembly to the pole at the desired height on the pole. The bracket is mounted to the pole using BAND-IT stainless steel bands. DO NOT SUBSTITUTE bands of other material or other widths! There are 3 locations for the PM3/M and ALL 3 slots MUST BE USED.

The required material for “inland” environments is:

BAND-IT # C206R9 stainless steel bands  
BAND-IT # C25699 buckles  
BAND-IT # C00169 tensioning tool

The stainless steel band is Type 201SS 0.030 inches (0.762mm) thick and 0.750 inches (19mm) wide. **This banding material should be used for “inland” environments. See below for ocean front and Marine environments.**

**NOTE:** For ocean front and marine environments, the only approved material is noted below:

BAND-IT # C406R9 stainless steel bands (316 stainless steel)  
BAND-IT # C45699 buckles (316 stainless steel)  
BAND-IT # C00169 tensioning tool

The stainless steel band is 316 grade 0.030 inches thick by 0.750 inches wide

**WARNING:** Do NOT substitute banding materials or banding dimensions.

Installation instructions from BAND-IT should be followed exactly. Operating instructions are supplied with the tensioning tool. (All BAND-IT parts and tools purchased separately. These parts and tools are not supplied by ONE SYSTEMS)

The stainless steel banding material, buckles and tensioning tools are available from the following locations (or through distributors recommended by these locations):

BAND-IT IDEX, Inc.  
4799 Dahlia St.  
Denver Colorado 80216  
USA  
1-800-525-0758

FELIX PONCE  
Calle Ignacio Zaragonza No. 8  
Colonia Ahuehuetes Atizapan 52953  
Edo. de Mexico  
(52) 555825 8502

BAND-IT Company Limited  
Speedwell Industrial Estate  
Stavely, Nr. Chesterfield  
Derbyshire, S43 3PF England  
Home Sales (44) 1246-479479  
Export Sales (44) 1246 479480

BAND-IT Clamps (ASIA) Pte. Ltd.  
11 Second Chin Bee Road  
Singapore 618777  
65-62658853

BAND-IT Shanghai Sales Office  
207 room  
Wanbao International Business Centre  
660# Xinhua Road  
Shanghai, China 200052  
021-62826348-308

Now the M8 forged shoulder “eye” bolt should be installed in the top rear of the loudspeaker enclosure. Make sure that that eyebolt is seated on the enclosure surface.

Note that the desired pan and tilt angles may be set either before or after the loudspeaker is mounted to the PM3/M assembly. However, the pan and tilt angle adjustments must be double checked and tightened after the loudspeaker has been mounted.

Next, the loudspeaker should be mounted to the PM3/M speaker mount bracket using the supplied M8 stainless steel bolts and internal tooth lock washers. **DO NOT SUBSTITUTE ANY PARTS.**

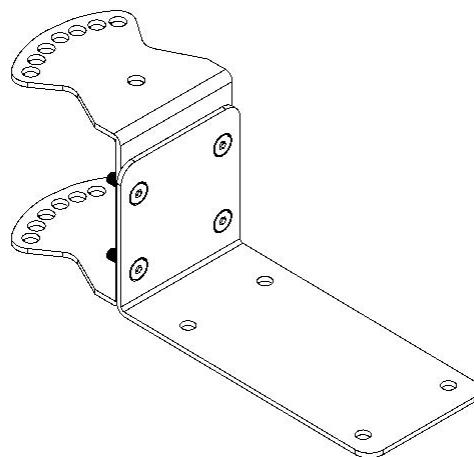

PM3/M speaker mount bracket section

The PM3/M mounts to the bottom of the 108/HTH, 108/HTC or 208/HTC using the M8 locations. The mounting locations are highlighted in red.

**Note:** Remove all M8 cover plugs before installing the loudspeaker on the PM3/M bracket plate!

**DO NOT SUBSTITUTE MOUNTING LOCATIONS!**



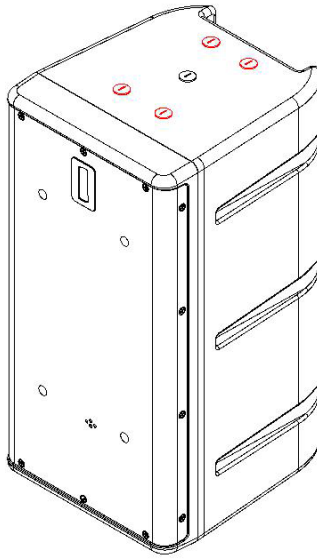

PM3/M Mounting locations (bottom ONLY) for 108/HTC, 108/HTH or 208/HTC

There are mounting locations on the bottom only of the 108/HTC, 108/HTH or 208/HTC

**USE EXTREME CAUTION!** The loudspeaker is heavy and it is likely that the desired mounting location is high in the air. This process should never be attempted by a single person.

TWO PEOPLE ARE REQUIRED TO MOUNT THE LOUDSPEAKER ENCLOSURE TO THE POLE AND BRACKET. Safety harnesses should always be worn when working from an elevated platform. The loudspeaker and loudspeaker section of the bracket may now be joined to the pole section and the required pan and tilt angles selected. This is a two person job and extreme care should be exercised to avoid serious injury.

The pan pivot bolt should be inserted first and secured but not completely tightened using the nylon insert nuts supplied. The pan pivot bolt is shown below in Figure 2d. Then the pan aiming bolt should be inserted and nylon insert nuts applied.

**CAUTION: DO NOT REMOVE THE PAN PIVOT BOLT AFTER INSERTION!**

Next the pan angle may be adjusted by removing the pan aiming bolt and setting the desired pan angle and then re inserting the bolt. **DO NOT REMOVE THE PAN PIVOT BOLT!**

The tilt angle may be adjusted by removing the tilt aiming bolt and setting the desired angle. **DO NOT REMOVE THE TILT PIVOT BOLT!**

After both the tilt and pan angles are set, make sure that all bolts are tight and secure.

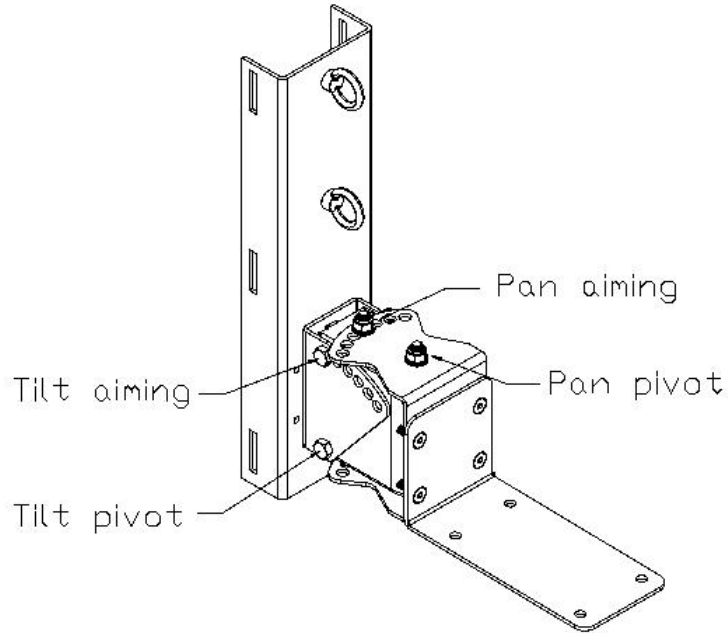
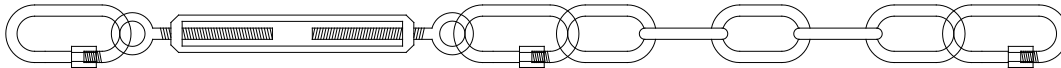

FIGURE 2d

UNDER NO CIRCUMSTANCES SHOULD THE LOUDSPEAKER DOWN TILT EXCEED 40 DEGREES FROM VERTICAL FOR THE PM3/M!

### LINK ASSEMBLY



Now the Link must be installed.

### **INSTALLING the PM3/M BRACKET WITHOUT THE LINK IS NOT ALLOWED!**

The Link consists of stainless steel quick links, a stainless steel turnbuckle, and several links of stainless steel chain. The use of the chain pieces and quick links with the turnbuckle is based on the tilt angle of the enclosure. The turnbuckle should always be used.

### **DO NOT SUBSTITUTE ANY PART OF THIS LINK ASSEMBLY!**

The Link should be tightened by rotating the turnbuckle until there is **VERY SLIGHT** tension on the Link assembly. Do not over tighten. The purpose of the Link is to provide support for the main Pole Mount System tilting bracket at the bottom of the assembly.

**Warning:** If the turnbuckle assembly is turned and the loudspeaker enclosure angle begins to change (if the down tilt angle begins to move toward 0 degrees vertical) then the turnbuckle has been **OVER TIGHTENED**. Turn the turnbuckle until there is **VERY slight** tension on the Link assembly and the down tilt of the enclosure is set by the tilt bolts on the PM3/M.

The back plate section of the PM3/M has two eyebolts attached to it. The figure below illustrates the proper eye bolt to use for each down tilt angle of the bracket.

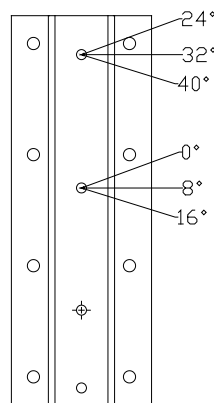

### PM3/M EYE BOLT AIMING LOCATIONS

Make sure to use the appropriate combination of Link parts to insure proper connection between the PM3/M and the specific One Systems enclosure. The required combination of Link parts is determined by the down tilt angle of the enclosure.

The assembly may be configured with any combination of turnbuckle, chain link sections and quick link in order to achieve the proper tension on the system, but the turnbuckle must always be used. The figures below show a 108/HTH or 208/HTC and PM3/M at vertical, 24 degrees and 40 degrees using the eyebolt positions shown in the PM3/M BOLT AIMING LOCATIONS" image. Note that Figure 8a and 8b use the same link and turnbuckle combination but different eyebolt locations and the Figure 8c uses chain sections as well as the quick links and the turnbuckle.

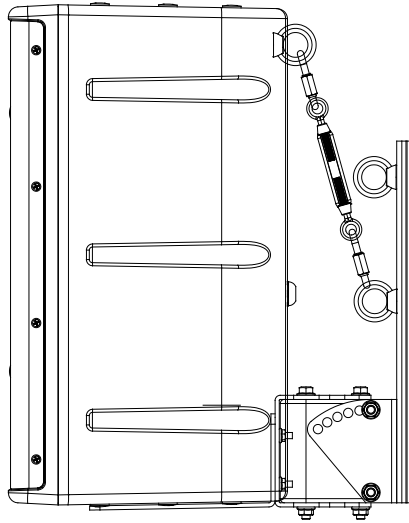

Figure 8a

This image represents the Link assembly with the enclosure in a vertical orientation and the Link using the lower eyebolt position

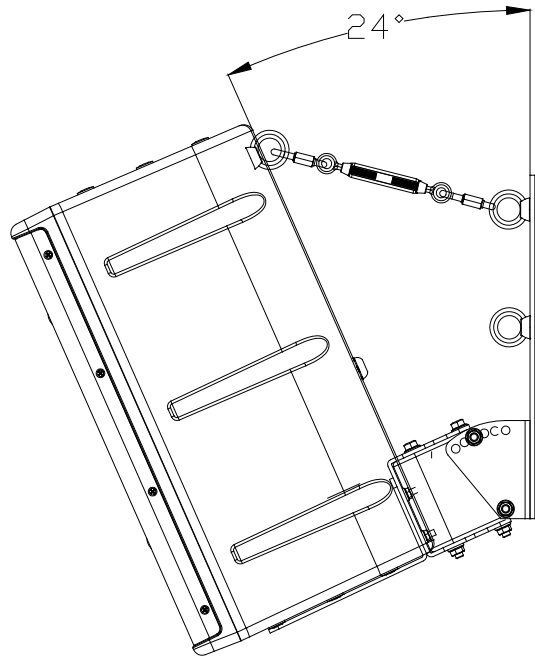

Figure 8b

Figure 8b represents the Link with the enclosure in a 24 degree tilt. The Link is using the top eyebolt and the turnbuckle has been adjusted to provide **VERY MILD** tension.

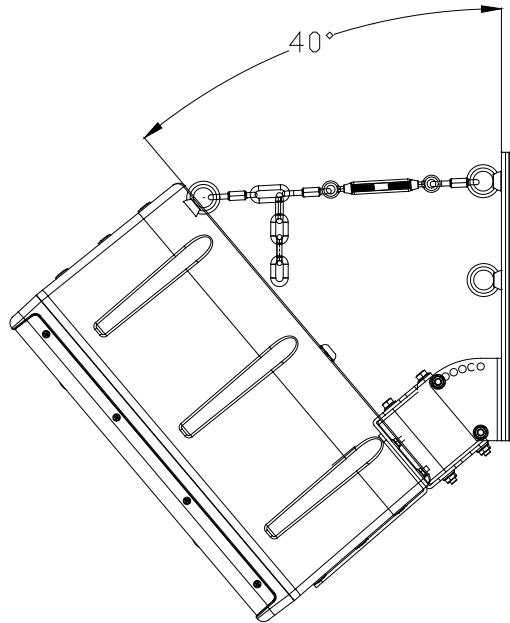

Figure 8c

Figure 8c represents the Link assembly with the enclosure in a 40 degree tilt. The Link assembly uses the top eyebolt and the stainless steel chain has been added to achieve the proper tension on the assembly. Notice the “dropped” chain links in Figure 8c.

**Warning:** If the turnbuckle assembly is turned and the loudspeaker enclosure angle begins to change (if the down tilt angle begins to move toward 0 degrees vertical then the turnbuckle has been OVER TIGHTENED. Turn the turnbuckle until the down tilt angle is set by the tilt axis bolts on the pole bracket and there is VERY slight tension on the Link assembly.

Figure 10 is a close up view of the Link assembly. Certain down tilt angles may require a link to be “dropped” from the chain as shown below. The lower quick link is positioned in various chain segments based on the desired degree of down tilt. The turnbuckle should be adjusted, as described in this section.

In any position, the turnbuckle must be adjusted to allow the proper amount of tension on the Link. The Link should never pull the loudspeaker up towards vertical. The Link may be configured with or without the chain section and quick link depending on the down tilt angle of the enclosure.

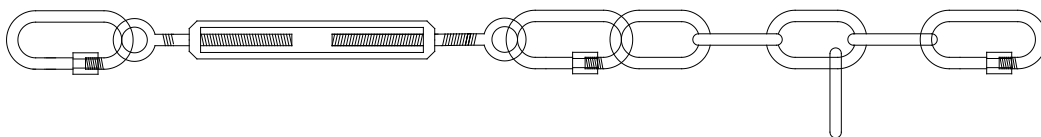

Figure 10

Secondary safety cables are **STRONGLY** recommended and should be secured to a structural point **NOT** associated with the Pole Mount or Pan/Tilt brackets or loudspeakers. The Link assembly is **NOT** a secondary safety! One Systems does **NOT** supply a secondary safety.

## APPENDIX 1

### (Projected Area Values)

The values below should be supplied to the specific pole manufacturer for safety calculations. These values were determined by adding the projected areas of the high frequency horns, the woofer cones and ports to the cross sectional area of the front of each enclosure listed below. Each enclosure will present a different EPA based on wind direction. The values listed below are for wind loads directly into the front of the enclosure and represent maximum values.

108/HTH.....	250 in <sup>2</sup> (161, 290mm <sup>2</sup> ) (60x40 HF horn)
208/HTC.....	207 in <sup>2</sup> (133, 550mm <sup>2</sup> )
108/HTC.....	169.4in <sup>2</sup> (109, 278mm <sup>2</sup> )

**The products referenced in this manual are in conformity with the following standards or other normative documents: Machinery Directive 2006/42/EC**