



Q SERIES DELUXE ACOUSTIC RECESSED ENCLOSURES FOR 8", 12", & 15" LOUDSPEAKERS

Q418, Q438, Q4412, Q458, Q4612, Q4712, Q4812, Q4915, QR30



PROBLEM / SOLUTION

Professional sound contractors and design engineers have long had a requirement for large loudspeaker enclosures for use in quality distributed sound systems. To meet the necessity for an acoustically acceptable quality enclosure, $\frac{3}{4}$ " (19mm) plywood enclosures had to be custom made for the sound contractor by local wood fabricators.

Although the wood enclosure offered the system designer acceptable acoustical qualities for professional sound reproduction, minimal vibration, little or no "hangover", it did present the sound contractor additional problems - hanging the enclosure in the ceiling, mounting available speaker baffles, meeting building fire codes and having such enclosures readily available from stock.

In response to the industry's need, Atlas Sound developed the "Q" Series enclosures which have comparable acoustical qualities to $\frac{3}{4}$ " (19mm) plywood and eliminate all the associated problems. Through a unique combination of acoustic board and metal with the engineered placement of "anti-vibration" ribs, Atlas Sound has achieved the acoustical qualities of $\frac{3}{4}$ " (19mm) plywood but with the general benefits afforded by metal enclosures. "For Your Information" sheet number SL3-1131, details lab results of the remarkable achievement by Atlas Sound to develop this new approach to quality enclosures.

GENERAL DESCRIPTION

Q Series enclosures have a unique acoustical fiber board permanently affixed to the inner walls of the enclosure which effectively eliminates the "hangover" and vibration normally associated with large metal enclosures. To achieve additional rigidity, unique ribs are formed on the back side of the enclosure. In addition, the inner walls are lined with $1\frac{1}{2}$ " (38mm) thick fiberglass with a $1\frac{1}{2}$ lb./cu.ft. density to control unwanted resonances in the high end of the frequency spectrum.

The "Q" Series enclosures are constructed of 18 gauge cold rolled steel. Compound $\frac{1}{2}$ " - $\frac{3}{4}$ " (13mm-19mm) knockouts are furnished on all four sides. The front mounting panel of the enclosure is constructed of sturdy 18 gauge steel and incorporates the baffle mounting plaster ring. This panel is isolated by means of a foam gasket to prevent metal to metal contact.

Two sets of slotted mounting tabs are welded on parallel sides to accept Model QR30 mounting channels (optional) for mounting the enclosure in the ceiling. These mounting tabs may also be used for any specific mounting technique developed by the installer. It is important that the sound contractor take particular note of the weight of these enclosures to determine suitable mounting procedures.

The entire metal enclosure is finished in black textured epoxy. Models with a volume of 1-3 cu. ft include $\frac{1}{2}$ " fiberboard. Models with a volume of 4-6 cu. ft include 1" fiberboard.

THREE

Specifications subject to change without notice



1601 JACK MCKAY BLVD. / ENNIS, TEXAS 75119 U.S.A.
TELEPHONE: (800) 876-3333 / FAX (800) 765-3435

AtlasSound.com

RECOMMENDED MOUNTING CHANNELS (OPTIONAL)

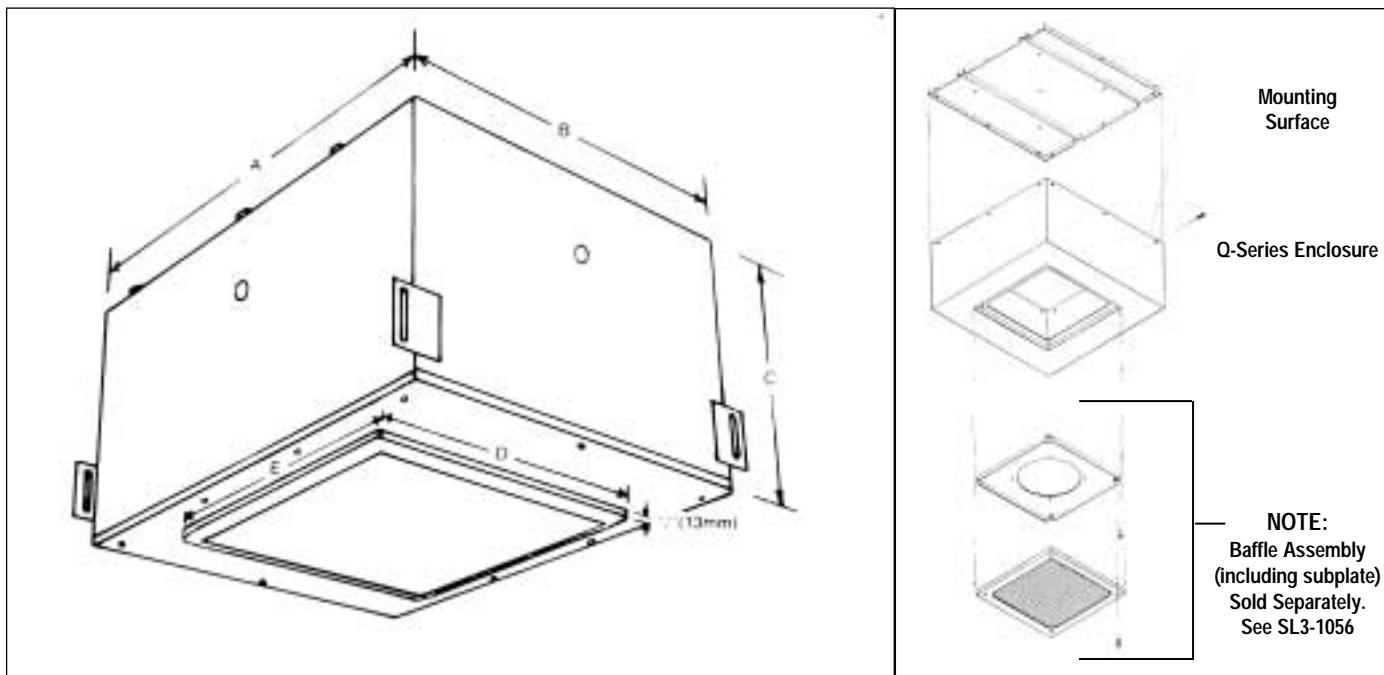

- Installation of "Q" Series enclosure can be facilitated through the use of Model QR30 channels which are 30" (762mm) long.
- Channels are constructed of 16 ga. CRS, packed in pairs, and finished in black epoxy.

ARCHITECT AND ENGINEER SPECIFICATIONS

The metal enclosure shall be Atlas Sound Model _____ (Q418, Q438, Q4412, Q458, Q4612, Q4712, Q4812, Q4915) or approved equal. The enclosure shall be constructed of 18 gauge cold rolled steel and shall have four combination 1/2" (13mm) - 3/4" (19mm) knockouts. Enclosure shall have a cubic content of _____ [1 1/2 ft³ (0.42m³), 2 ft³ (0.54m³), 3 ft³ (0.81m³), 4 ft³ (1.13m³), 6 ft³ (1.66m³)]. Acoustic fiber board shall be affixed to the inner walls of the enclosure. Inner walls of the enclosure shall also be lined with 1/2" (38mm) thick fiberglass with a 1 1/2 lb./cu. ft. density.

Reinforcing ribs shall be formed on the back side of the enclosure. Front mounting panel shall incorporate the baffle mounting plaster ring and shall be isolated by means of a foam gasket to prevent metal to metal contact. Enclosure shall have four slotted mounting tabs welded to the side for use with mounting channels. The enclosure shall be finished in black epoxy. Enclosure shall mount Atlas Sound Model _____ loudspeaker baffle or approved equal

Model No.	Cubic Size Ft3 (m3)	Speaker Size	Dimensions					Mounts Baffle Model
			A	B	C	D	E	
Q418	1 1/2 (.042)	8" (203mm)	18" (457mm)	18" (457mm)	8" (203mm)	11 3/4" (298mm)	11 3/4" (298mm)	19-8, 164-8
Q438	2 (.054)	8" (203mm)	23" (584mm)	18" (457mm)	8" (203mm)	11 3/4" (298mm)	11 3/4" (298mm)	19-8, 164-8
Q4412	2 (.054)	12" (305mm)	23" (584mm)	18" (457mm)	8" (203mm)	14 5/8" (371mm)	14 5/8" (371mm)	164-12
Q458	3 (.081)	8" (203mm)	23" (584mm)	18" (457mm)	12" (305mm)	11 3/4" (298mm)	11 3/4" (298mm)	19-8, 164-8
Q4612	3 (.081)	12" (305mm)	23" (584mm)	18" (457mm)	12" (305mm)	14 5/8" (371mm)	14 5/8" (371mm)	164-12
Q4712	4 (.113)	12" (305mm)	23" (284mm)	18" (457mm)	16 1/2" (425mm)	14 5/8" (371mm)	14 5/8" (371mm)	164-12
Q4812	6 (.169)	12" (305mm)	29 1/2" (749mm)	23" (584mm)	15" (381mm)	14 5/8" (371mm)	14 5/8" (371mm)	164-12
Q4915	6 (.169)	15" (381mm)	29 1/2" (749mm)	23" (584mm)	15" (381mm)	19 1/4" (489mm)	19 1/4" (489mm)	164-15

Model No.	Enclosure Wt. Less Speaker	Optional Mounting Channels
Q418	21 lbs.(9.53kg)	QR30 30" (762mm) long
Q438, Q4412	25 lbs.(11.34kg)	
Q458, Q4612	30 lbs.(13.61kg)	
Q4712	44 lbs.(19.96kg)	
Q4812, Q4915	58 lbs.(26.31kg)	

Specifications subject to change without notice



1601 JACK MCKAY BLVD. / ENNIS, TEXAS 75119 U.S.A.
TELEPHONE: (800) 876-3333 / FAX (800) 765-3435

AtlasSound.com