

Rack Panel Kit Instructions

Model RPK 005 Single Rack Panel Kit, and Model RPK 006 Dual Rack Panel Kit
For use with Williams Sound 1/2 rack products

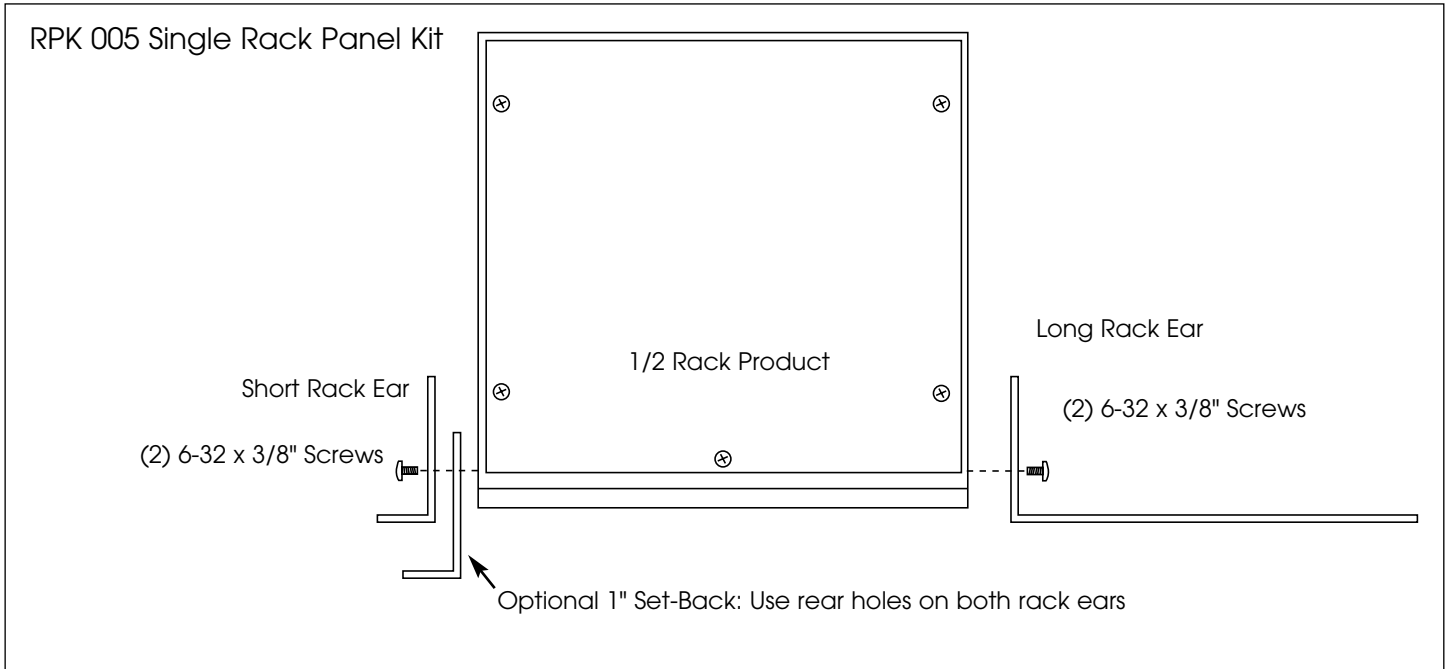

RPK 005 Installation Steps

- Step 1:** Attach the short and long rack ears as shown with four 6-32 x 3/8" machine screws. Use the front set of holes on the rack ears for a flush mount. Use the rear set of holes on the rack ears for a 1" recessed mount.
- Step 2:** Attach the rack panel assembly to the rack with the machine screws and nylon washers provided.

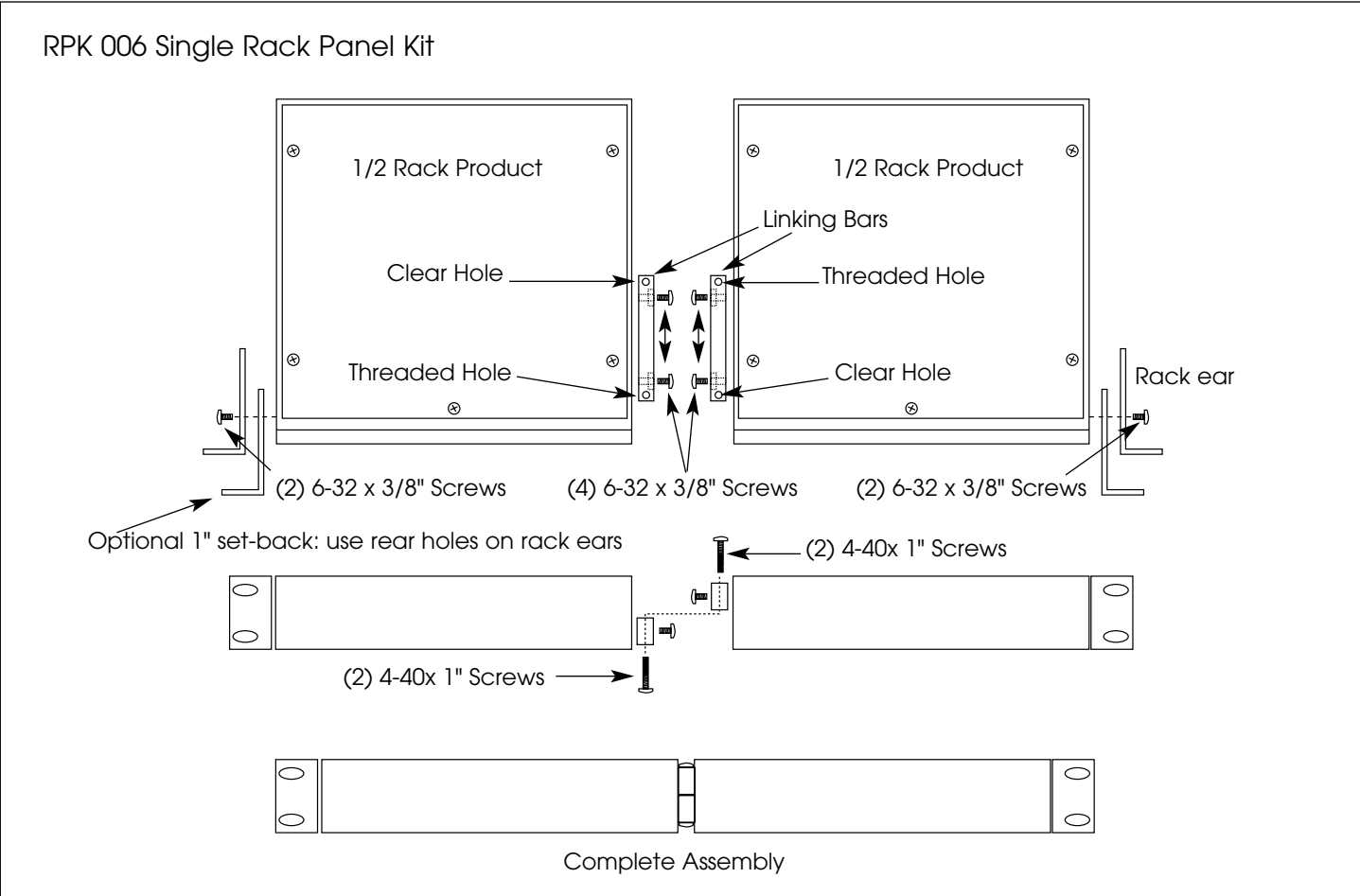

RPK 006 Installation Steps

- Step 1:** Attach the short rack ears as shown with four 6-32 x 3/8" machine screws. Use the front set of holes on the rack ears for a flush mount. Use the rear set of holes on the rack ears for a 1" recessed mount.
- Step 2:** Attach the linking bars to each 1/2 rack unit as shown with four 6-32 x 3/8" machine screws. Be sure to install the linking bars so the clear hole in one bar is next to the threaded hole in the other.
- Step 3:** Place the two 1/2 rack units together, so the linking bars overlap. Use four 4-40 x 1" machine screws to tie the linking bars together, as shown in the lower drawing.
- Step 4:** Attach the rack panel assembly to the rack with the machine screws and nylon washers provided.

RECYCLING INSTRUCTIONS



Help Williams Sound protect the environment! Please take the time to dispose of your equipment properly.

Product Recycling for Customers in the European Union:

Please do NOT dispose of your Williams Sound equipment in the household trash. Please take the equipment to a electronics recycling center; OR return the product to the factory for proper disposal.



8/16/06



WILLIAMS SOUND®
Helping People Hear

10321 West 70th St., Eden Prairie, MN 55344 U.S.A.
800.843.3544 | 952.943.2252 | FAX: 952.943.2174
www.williamssound.com