

### Description

Lowell grille Model FW-12 is an attractive, beveled edge steel grille with a fine-perf center and a separate speaker-to-backbox adapter plate. The grille and adapter are designed to mount 12" speaker drivers (except Model 12Q250) to Lowell large-volume acoustic backbox Models DX1312 (1.9 cu.ft.), DX1512 (2.9 cu.ft.), DX1612 (4.0 cu.ft.) and DX1712 (5.9 cu.ft.).

Model FW-12 grille is an 18-gauge, one-piece perforated steel grille with adapter plate and mounting hardware. The grille features a 12.125" x 12.125" perforated area with a beveled edge frame for attractive ceiling integration. The grille is finished in Lowell's white powder epoxy paint for long lasting quality appearance. The adapter (included) is fabricated from 20-gauge steel and is finished with black powder epoxy paint. The adapter includes corrosion-resistant 8-32 x 1-1/2" screws and clinch nuts for mounting a 12" driver with an 11.625" Dia. bolt pattern such as Lowell Model 12P150 (150W) to Lowell's DX Series 12" speaker backboxes. The direct mount speaker-adapter to backbox installation method allows a high quality 12" driver with substantial motor structure to be supported by the backbox allowing the non-loadbearing FW-12 grille to mount using four 8-32 x 3/8" screws. See page 2 for backbox and channel rail information.

*Note: if driver Model 12Q250 is specified, similar grille Model FW12Q with ported subplate must be used.*

### A & E Specifications

The grille for 12" speaker drivers shall be Lowell Model FW-12. It shall be one-piece 18-gauge steel with a perforated center and beveled frame. It shall include a 20-gauge steel adapter plate and mounting hardware. The grille shall be 15.25" SQ with a mounting projection of 0.375". The adapter plate shall include hardware for mounting a 12" driver and for mounting the adapter-driver assembly to Lowell backbox Model \_\_\_\_ (DX1312, DX1512, DX1612, DX1712). The adapter shall be finished in black powder epoxy. The grille shall be finished in white powder epoxy. It shall be non-loadbearing and mount to the specified backbox using four 8-32 x 3/8" white screws.

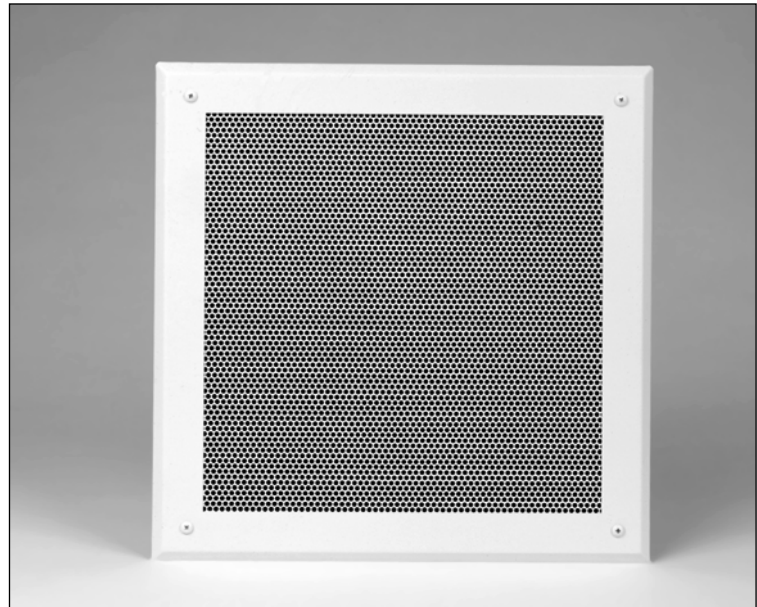

**FW-12**  
Grille for mounting a 12" speaker to DX Series 12" backboxes

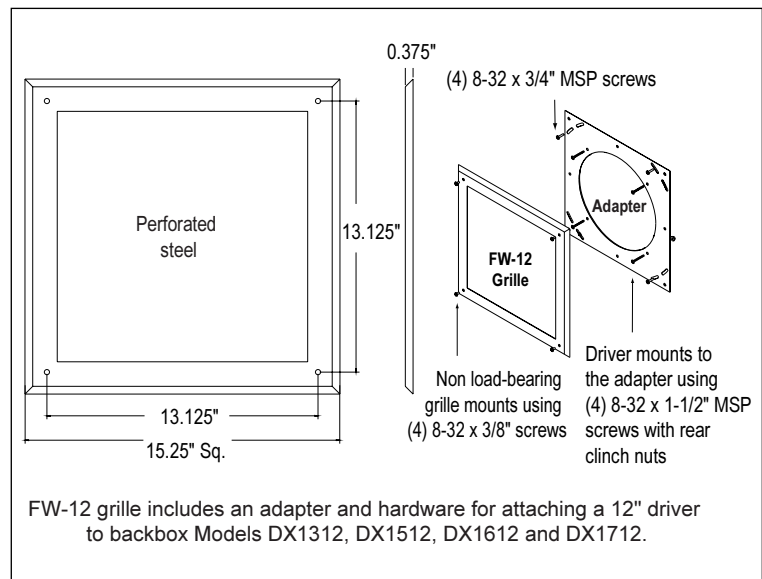

### Grille Specifications and Companion Mounting Accessories (order separately)

Grille Model	Speaker Size*	Grille Size	Mounting Provisions	Material	Color	Backbox Choices (Choose one, plus rails if required)	+	Channel Rails (if required for suspended ceilings)
FW-12	12"	15.25" Sq.	4 Screws, Adapter w 4 screws	Steel	White	DX1312, DX1512 DX1612 (includes eyebolts), DX1712 (includes eyebolts)		SS30, SS48 rails N.A. (flyware by others)

\*Specify Lowell's high performance 12" speaker Model 12P150 (150W) for use with grille Model FW-12 and backbox Series DX. *Note: if driver Model 12Q250 is specified, similar grille Model FW12Q with ported subplate must be used.*



**FW-12**

Grille with screw-mount installation for 12" speakers

**A  
U  
D  
I  
O**

**Companion mounting accessories for grille Model FW-12** (order separately)



DX1312 / DX1512  
DX1612 / DX1712



SS Series

**Backbox Details** (Choose one backbox plus rails if required)

Model	Size	Features	Mounts Speaker	Mounts Grille
DX1312	23"L x 18"W x 8"D	1.9 cu.ft., Extended lip, 1.5" thick batting		
DX1512	23"L x 18"W x 12"D	2.9 cu.ft., Extended lip, 1.5" thick batting	12"	FW-12
DX1612	23"L x 18"W x 16.75"D	4.0 cu.ft., Extended lip, 1.5" thick batting, eyebolts*		
DX1712	29.5"L x 23"W x 15"D	5.9 cu.ft., Extended lip, 1.5" thick batting, eyebolts*		

\*Factory installed eyebolts are 1/4" - 20 forged construction.

**Channel Rail Details** (use rails if required for suspended ceiling)

Model	Size
SS-30	30"L
SS-48	47.75"L

**12"/10"**  
Speakers & Accessories

**8"**  
Speakers & Accessories

**6"**  
Speakers & Accessories

**4"**  
Speakers & Accessories

**Horn**  
Speakers & Accessories

**Masking**  
Speakers & Generators

**Control**  
Accessories & Electronics

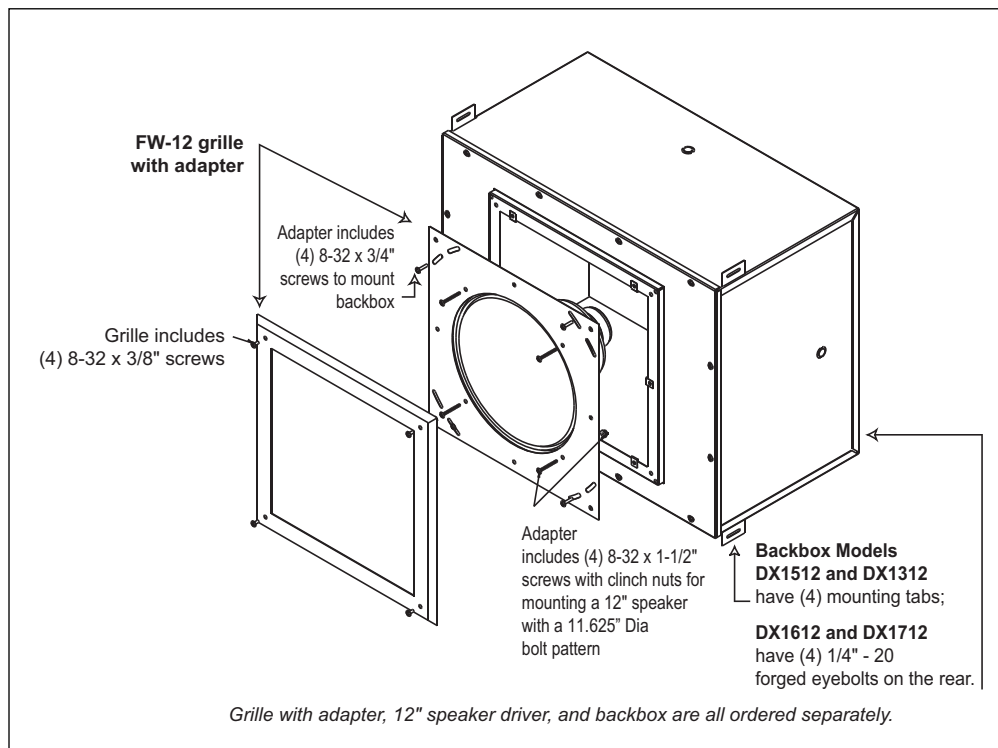

Grilles - Ceiling / Wall