

0401.1 - FLUSH MOUNTED, ROUND

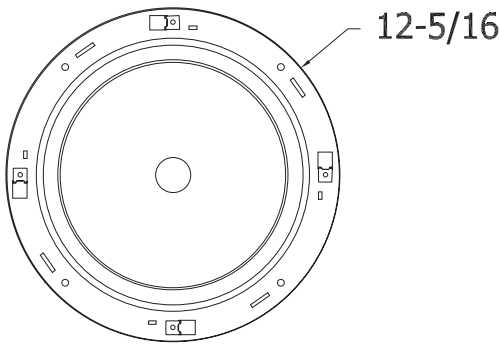
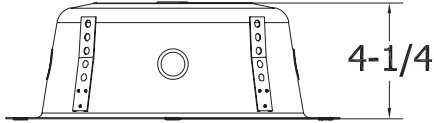

GENERAL DESCRIPTION

The Quam ERD-8 or ERD8U is a UL Listed (UUMW), round, steel loudspeaker back box. Finish: White baked epoxy hybrid.

INTENDED USE

Use with recommended additional Quam components to complete a loudspeaker assembly used in an indoor environment.

SYSTEM COMPONENTS

N/A

RECOMMENDED ADDITIONAL QUAM COMPONENTS

0402 - Loudspeaker Mounting Devices, SSB-2

0401.2 - Speaker, Transformer, Baffle & Volume Control
OR

0104.3 - Speaker, Transformer, Baffle & Universal Knob Control

MECHANICAL SPECIFICATIONS

Height	4-1/2"
Diameter (Flange Max)	12-5/16"
Bottom Diameter	9-3/4"
Top Diameter	8-1/2"
Internal Displacement	275 cu. in.

ATTACHMENT POINTS

	TOP	SIDE
ERD-8	--	4x welded
ERD8U	--	2x snap-in

ELECTRICAL ACCESS

	TOP	SIDE
ERD-8	1x	4x - 90° apart
ERD8U	1x	4x - 90° apart

All devices connect with twist-tabs to support bridge.

Recommended construction sequences, installation instructions and A&E Specifications are available in various formats on the Quam Architects' and Engineers' Resources CD or on the web at www.quamspeakers.com

Quam-Nichols Company

234 East Marquette Road, Chicago, IL 60637
Phone (800) NEED NOW Fax (888) NEED NOW
(800) 633-3669 (888) 633-3669

E-Mail: neednow@qnc.com www.quamspeakers.com

