

VCM™ INVERTED HEAVY-DUTY PROJECTOR MOUNT

Provides strong support for mounting heavy projectors in schools and auditoriums.

Built-In Lateral Shift
1-1/2" (38 mm) forward/back and side/side.

Quick Projector Connect/Disconnect
With convenient lamp and filter access.
– Always maintains registration
– Disconnecting doesn't affect pre-set adjustments

3 Mounting Options:

1. Flush mount to suitable ceilings – LPK-1 Low-Profile Mounting Kit required.
2. 1/2" (13 mm) Threaded Rod using the four corner slots in the top of the mount.
3. 1-1/2" NPT Threaded Extension Column using the threaded opening at the top of the mount.

Note: LPK-1, Threaded Rod and Extension Column not included.

Integrated Cable Management

Independent Adjustments
Exclusive micrometer roll and pitch adjustments are made with the alignment features of the body, enabling you to remove the projector without disturbing alignment.

Steel-into-Steel Construction
Heavy-duty design securely mounts large, heavy projectors.

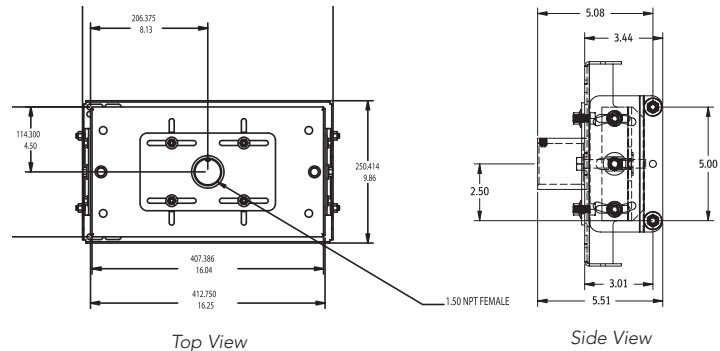

SPECIFICATIONS		RECOMMENDED ACCESSORIES	PAGE
Roll	+/-5°	CMA-100 8" (203 mm) Ceiling Plate with Attached Adjustable 1-1/2" NPT Column	22
Pitch	+/-20°	CMA-110 8" (203 mm) Ceiling Plate with 1-1/2" NPT Opening	22
Yaw	360°	CMA-340 Support Bracket and Cable Assembly	26
Color	Black	CMA-450 Suspended Ceiling Kit	23
Weight		CMA-455 Suspended Ceiling Replacement Kit	23
Capacity	250 lbs (113.6 kg)	LPK-1 Low-Profile Flush Mounting Kit	24
		QD-1 Quick-Disconnect	26
		XY-1 Heavy-Duty Lateral Shift Bracket	26
		CMA Fixed and Adjustable Extension Columns	24