



Quam

CIS4
2-Gang, Vandal Resistant Call-In Station, Stainless Steel

CIS2
3-Gang, Vandal Resistant Call-In Station, Stainless Steel

0602- VANDAL RESISTANT INTERCOM ASSEMBLY

CIS4/25 SHOWN

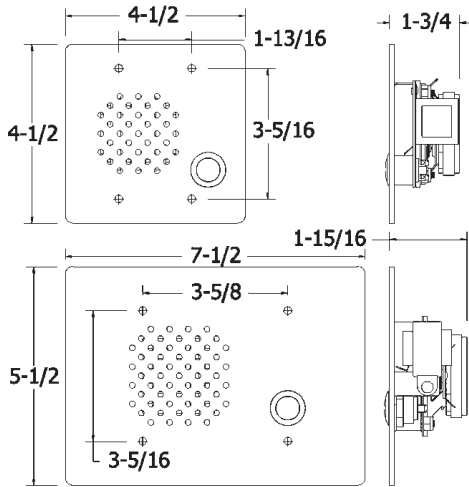

CIS2/25 SHOWN



CIS4 SHOWN

GENERAL DESCRIPTION: All variants

The Quam CISx/xx is a complete vandal resistant call-in station with integral speaker/ microphone and momentary, normally open, push-to-call button. The faceplate is 12 gage, brushed stainless steel with tamper-resistant hardware. An optional red, mushroom button can be substituted at extra cost at time of order.

Specify 8 or 45 Ohm impedance voice coil or 25 or 70.7V multi-tap transformer, at time of order.

The Quam CIS4/xx, as above in 2-gang wide format.

The Quam CIS2/xx, as above in 3-gang wide format.

INTENDED USE: All variants

Exterior or interior use

Program Material: Signal tones and voice

SYSTEM COMPONENTS:

Loudspeaker:	3" weatherproof, (CIS2) 2-1/2" weatherproof, (CIS4) Phenolic impregnated cone
Transformer Option: 25V 70.7V	All versions, 5 taps at -3 dB levels Order CISx/25 with TBL25, 4W Order CISx/70 with B70, 4W
Voice Coil Option: 8 Ohm 45 Ohm	Order CISx/8 Order CISx/45

RECOMMENDED ADDITIONAL QUAM COMPONENTS:

CIS2/xx only:

0603 SE3WVP Vandal Resistant Enclosure

CIS4/xx only:

0603 SE6GVP Surface Mount Enclosure

0603 SE7GVP Hooded Enclosure

0603 SE8GVP Angled Enclosure

AUDIO SPECIFICATIONS:

Speaker Size:	3" CIS2, 2-1/2" CIS4
Average	87 dB SPL, 1W/ 1M
Sensitivity:	
Power Rating:	8W RMS, EIA 426A Standard
Calculated	93 dB SPL, 4W/ 1M
Output:	
Frequency	200Hz - 8kHz CIS4
Response:	150Hz - 10kHz CIS2 EIA 426A Standard
Nominal	90° Included Angle,
Coverage Angle:	-6 dB / 2 kHz, Half space
Audio	7" long, color-coded tinned wires,
Connection:	pre-cut, transformer only

Recommended construction sequences, installation instructions and A&E Specifications are available in various formats on the Quam Architects' and Engineers' Resources CD or on the web at www.quamspeakers.com

VANDAL RESISTANT INTERCOM ASSEMBLES

06

Quam-Nichols Company

234 East Marquette Road, Chicago, IL 60637

Phone (800) NEED NOW Fax (888) NEED NOW

(800) 633-3669 (888) 633-3669

E-Mail: neednow@qnc.com

www.quamspeakers.com

