

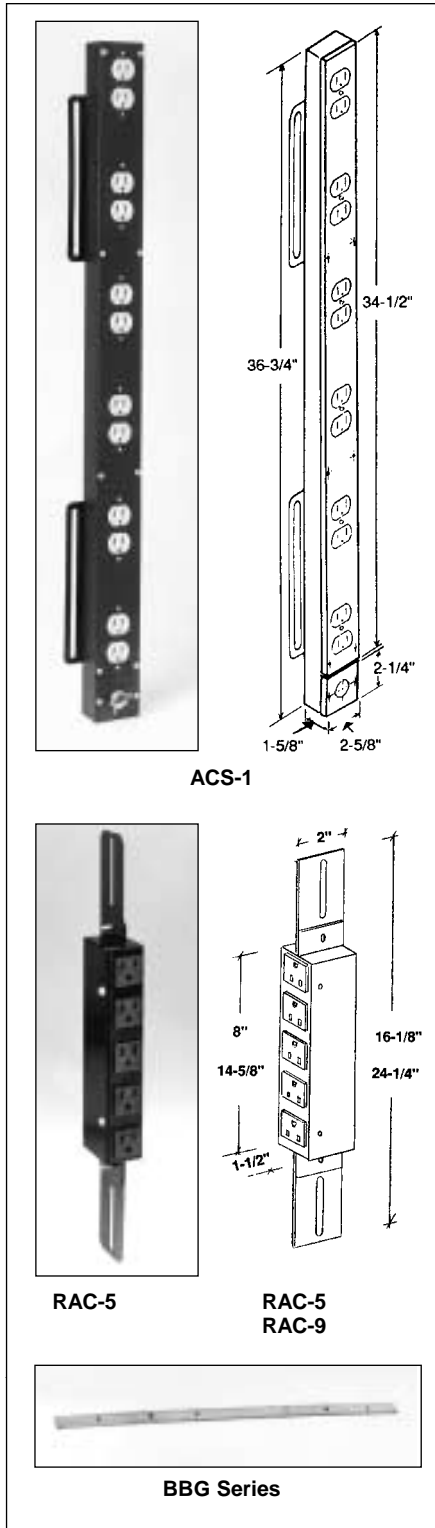

AC OUTLET STRIPS /COPPER BUS BARS

ACS-1, RAC-5, RAC-9,
BBG Series



AC OUTLET STRIPS

Install Atlas Sound outlet strips in equipment cabinets and consoles for convenient AC electrical connections. Units may be used in conjunction with Atlas Sound fan assemblies and power panels to provide a complete cooling and AC power distribution system.

ACS-1/ACS-1A/ACS-2A. Outlet strip includes six grounded duplex outlets for installation in equipment cabinets with vertical panel space greater than 36". May be used in conjunction with Atlas Sound fan assemblies and power panels to provide a complete cooling and AC power distribution system. Includes hardware. Finished in black epoxy. Dimensions are 36 3/4" L x 2 5/8" W x 1 5/8" H.

RAC-5(B)/RAC-9(B). Slimline outlet strips provide convenient electrical access without utilizing valuable cabinet space. Compact housing installs between cabinet side panel and mounting rails to the horizontal frame. Housings are finished in black epoxy. Dimensions for the RAC-5 models are 16 1/2" L x 1 1/2" W x 2" D. RAC-9 models measure 24 1/4" L x 1 1/2" W x 2" D.

MODEL	OUTLETS	OUTLET RATING	POWER CONNECTION	MOUNTS CABINETS
ACS-1	12 (6 Duplex)	15 Amps	6 ft. power cord	With P.O. greater than 36 3/4"
* ACS-1A	12 (6 Duplex)	15 Amps	6" Pigtails	
* ACS-2A	12 (6 Duplex)	20 Amps	6" Pigtails	
RAC-5	5	15 Amps	6 ft. power cord	5022, 5036, SMB22
* RAC-5B	5	15 Amps	6 ft. flex conduit	
RAC-9	9	15 Amps	6 ft. power cord	5042, 5061, 5070, (WA)200, WA202, 500, (WA)200.
* RAC-9B	9	15 Amps	6 ft. flex conduit	

* Isolated ground version.

COPPER BUS BARS

BBG Series. Depend on Atlas Sound's copper bus bars for convenient grounding of rack mounted equipment. To meet application requirements, bars are available in six lengths and mount to cabinet interiors with provided 1/4-20 x 1/2" hardware.

MODEL	LENGTH	WEIGHT
BBG-5022	22 3/4" (578mm)	1.75 lbs. (.8kg.)
BBG-5036	36 3/4" (933mm)	2.75 lbs. (1.25kg.)
BBG-5042	42" (1067mm)	3.25 lbs. (1.5kg.)
BBG-5061	61 1/4" (1556mm)	4.5 lbs. (2kg.)
BBG-5070	70" (1778mm)	5.25 lbs. (2.4kg.)
BBG-5077	77" (1956mm)	5.75 lbs. (2.6kg.)

ARCHITECT AND ENGINEER SPECIFICATIONS

Each equipment rack shall incorporate an Atlas Sound Model _____ (ACS-1, RAC-5, RAC-9) AC Outlet Strip or approved equal for proper AC power termination. Each strip shall include _____ (6 UL Listed duplex, 5 or 9) 15 amp grounded receptacles, six foot three-wire cord and mounting hardware. Construction shall be heavy gauge steel with black epoxy finish.

Copper bus bar shall be Atlas Sound Model _____ (BBG Series) or approved equal. The strip shall provide grounding of rack mounted equipment. Bus bar shall be 1/4" thick, 3/4" wide and mount in cabinet structures with 1/4-20 x 1/2" provided hardware.

Specifications subject to change without notice



1601 JACK MCKAY BLVD. / ENNIS, TEXAS 75119 U.S.A. / TELEPHONE: (800) 876-3333 / FAX (800) 765-3435