



SPECIFICATIONS

Loudspeaker Type:	3-way, horn loaded coaxial, weather-resistant
Operating Range:	90 Hz to 16 kHz 125 Hz to 12500 Hz (± 6 dB)
Max Input Ratings:	200W, 70/100V
Recommended Power Amplifier:	25W to 200W @ 70 Volts 50W to 200W @ 100 Volts
Sensitivity (1W/1m):	105 dB SPL (125 Hz to 10 kHz 1/3 octave bands) 106 dB SPL (250 Hz to 4 kHz speech range)
Maximum Output on 200W Tap:	128 dB SPL
200W Nominal Impedance:	25 ohms
200W Minimum Impedance:	12.1 ohms @ 11 kHz
Nominal -6dB Beamwidth:	60° H (+32° / -17°, 2 kHz to 10 kHz) 40° V (+33° / -1°, 2 kHz to 10 kHz)
Axial Q / DI:	20.5 / 13.1, 2 kHz to 12.5 kHz
Crossover Frequency:	600 Hz / 4 kHz
Recommended Signal Processing:	70 Hz high pass filter
Drivers:	LF (1) 12" weather treated, Ferrofluid-cooled MF (1) M200, Ferrofluid-cooled HF (1) 1" exit, titanium free, Ferrofluid-cooled
Driver Protection:	None
Input Connection:	12 foot (4 m) UV-resistant #18 gauge multi-conductor cable
Controls:	None
Enclosure:	Rotomolded HDPE, light grey
Mounting/Rigging Provisions:	(5) 3/8-16 rigging points
Grille:	3-layer WeatherStop™ (Perforated steel, foam, stainless steel mesh)
Required Accessories:	None
Supplied Accessories:	(1) Stainless steel (304) yoke bracket (1) Aiming strap
Optional Accessories:	Pole mount system
Dimensions—Height:	16 inches (406 mm)
Width:	16 inches (406 mm)
Depth:	16 inches (406 mm)
Weight:	45.5 lbs (20.6 kg)
Shipping Weight:	52 lbs (23.6 kg)



APPLICATIONS

- Primary loudspeakers for stadia and athletic fields
- Outdoor background music / paging systems
- Theme and amusement parks
- Fairgrounds, rodeos, air shows
- Malls, cruise ships, skating rinks
- Swimming pools
- Convention centers
- Portable sound systems
- Racetrack catch fence systems

FEATURES

- Rotomolded, UV enclosure
- Pattern control down to 630 Hz
- High efficiency
- Integral mounting points
- High power passive crossover
- Five-year product warranty / Fifteen-year enclosure warranty

DESCRIPTION

The R.5HPT is a three-way horn loaded weather-resistant loudspeaker system engineered to provide maximum intelligibility from a most compact design. By the packaging of Community's well-known M200 midrange driver coaxially within the mouth of the 12" LF horn, an extremely powerful tool for voice announcement systems was created. High frequencies are handled by Community's non-metallic diaphragm UC1 1" exit HF driver. An input autoformer with switchable taps provides impedance matching to 70V or 100V lines. The M200/UC1 creates effortless voice-power with HF sparkle that must be heard to be appreciated. No longer do audiences need to experience the unpleasant sound of "honky" re-entrant paging horns. The R.5HP can act as both a musical entertainment loudspeaker and a voice PA loudspeaker simultaneously. Each system is backed by Community's five-year product warranty and fifteen-year enclosure warranty.

NOTES:

1. Sensitivity: Free field pink noise measurement at 40 ft (12.2 m) at 60% power; extrapolated to 1 meter and an input of 2.45 volts RMS.
2. Watts: All wattage figures are calculated using the rated nominal impedance.



True to Specification

R.5HPT

3-WAY HORN LOADED WEATHER-RESISTANT FULL-RANGE 200W (70V/100V) LOUDSPEAKER

FREQUENCY RESPONSE

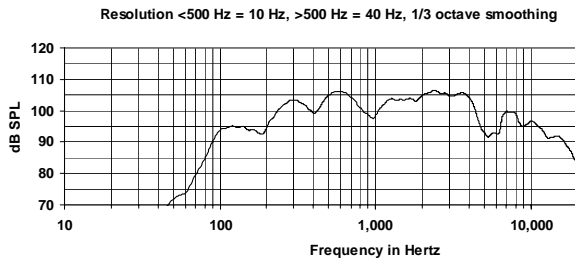

200W IMPEDANCE

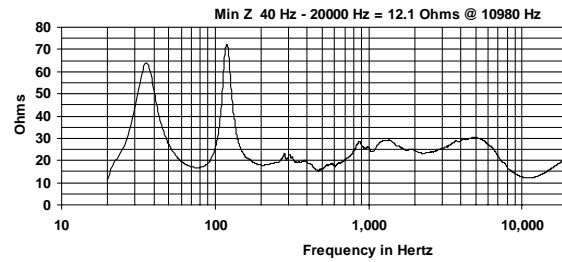

BEAMWIDTH

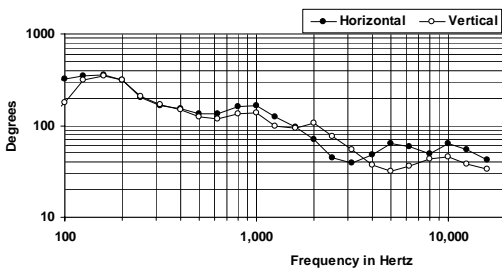

AXIAL Q

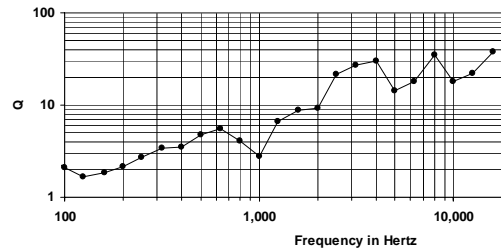

DIMENSIONS

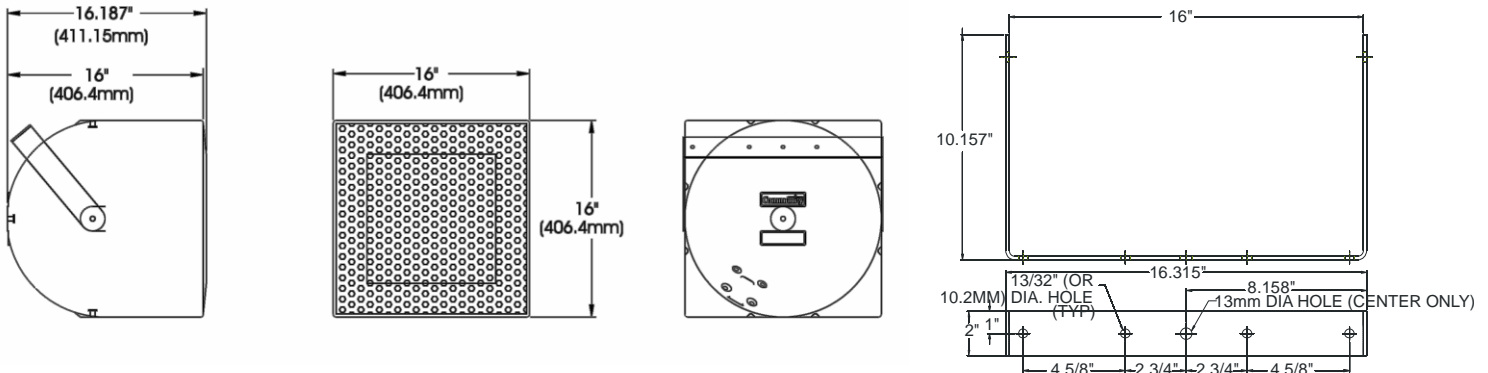

ARCHITECTURAL SPECIFICATIONS

The loudspeaker system shall be a horn-loaded, three-way, coaxial design consisting of one 12" Ferrofluid-cooled driver, one M200 Ferrofluid-cooled compression driver, and one 1" exit compression driver mounted on a horn inside the cabinet. The drivers shall be connected to a passive crossover network with crossover frequencies at 600 Hz and 4 kHz respectively. The cabinet shall be a roto-molded polyethylene enclosure providing weather and UV resistance with three layer weather resistant grille. The input connection shall be one 12' (4m) UV-resistant #18 gauge multi-conductor cable with stripped ends. The enclosure shall incorporate five 3/8-16 rigging points for multiple mounting options. In addition, the loudspeaker will be supplied with one stainless steel yoke bracket and one multi-tap autoformer for 70V and 100V inputs. The loudspeaker system shall have an amplitude response of 125 Hz-12.5 kHz (+/- 6 dB SPL), an input capacity of 200W (70V/100V), 106 dB SPL sensitivity @ 2.45V / 1 meter between 250Hz - 4kHz at a nominal 6 ohm impedance. The nominal dispersion shall be 60° x 40° over a frequency range of 2 kHz to 10 kHz. The dimensions of the enclosure are defined as 16" x 16" x 16" (HWD) at a weight of 45.5 lbs.

Community strives to improve its products on a continual basis. Specifications are therefore subject to change without notice.