



Quam

H16/RVP
 Paging Horn, Transformer, Vandal Resistant Round Baffle

H16/SVP
 Paging Horn, Transformer, Vandal Resistant Square Baffle

0103 - PAGING HORN

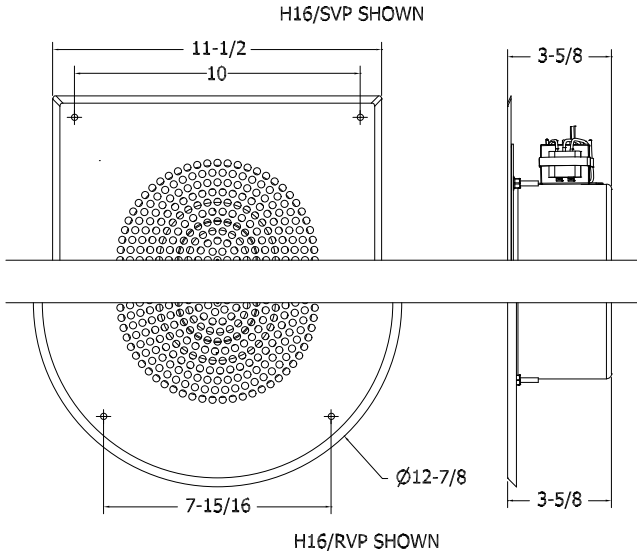

01
LOUDSPEAKER ASSEMBLIES

GENERAL DESCRIPTION

The Quam H16/xVP is a loudspeaker assembly with double re-entrant horn, compression type loudspeaker, 25 and 70.7V universal transformer, 16 gage steel baffle and #8 x 32 'pin-in-hex' hardware.
 Finish: White baked epoxy hybrid finish.

INTENDED USE

Outdoor, indoor environment, vertical or horizontal surface mount

Program Material: Signal tone and voice

SYSTEM COMPONENTS

Loudspeaker:	H16T
Transformer:	Integral to unit, 16W, 25V or 70.7V, 5 taps at -3dB levels*
Round Baffle:	BR8VP, Order as H16/RVP
Square Baffle:	BS8VP, Order as H16/SVP

*16W, 8W, 4W, 2W, 1W

RECOMMENDED ADDITIONAL QUAM COMPONENTS

- 0401.2 - Square, Flush Mounted Back Boxes
- 0602 - Vandal Resistant Intercom Assemblies
- 0603 - Vandal Resistant Components

AUDIO SPECIFICATIONS

Speaker Type:	Compression, re-entrant horn
Average Sensitivity:	110 dB-SPL, 1W / 1M
Power rating:	16W-RMS, EIA 426A Standard
Calculated Output:	121dB-SPL, 16W/ 1M
Frequency Response:	350 -10 kHz
Nominal Coverage Angle:	90° Included Angle, -6 dB / 2 kHz, Half Space
Audio Connection:	7" long, color-coded tinned wires, pre-cut

Recommended construction sequences, installation instructions and A&E Specifications are available in various formats on the Quam Architects' and Engineers' Resources CD or on the web at: www.quamspeakers.com

Quam-Nichols Company

234 East Marquette Road, Chicago, IL 60637
 Phone: (800) NEED NOW Fax: (888) NEED NOW
 (800) 633 - 3669 (888) 633 - 3669
 E-Mail: neednow@qnc.com www.quamspeakers.com