

BLOCK DIAGRAM

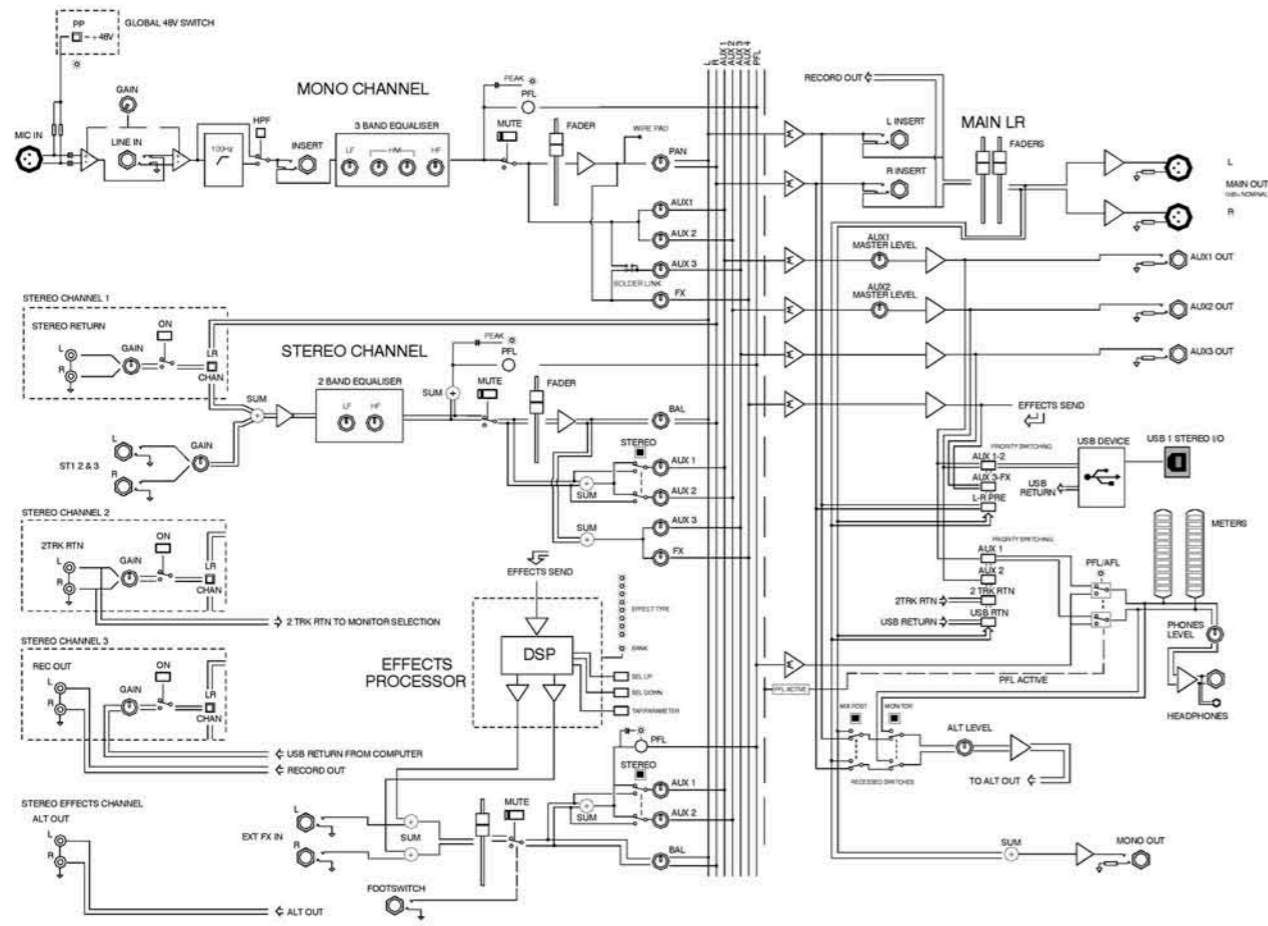

Small Format USB Mixers
Live Performance, Recording & Production

TECHNICAL SPECS

- Inputs**
Mono channel (XLR) Input +6 to -63dBu for nominal (+17dBu in max)
Mono channel Line Input (Jack socket) +10 to -26dBu (+30dBu max)
Insert point (TRS Jack socket) 0dBu nominal +21dBu max.
Stereo Input (Jack sockets) 0dBu nominal (control = Off to +10dB)
Stereo input (phono sockets) 0dBu nominal (control = Off to +10dB)
- Outputs**
L, R & Mono Outputs (L&R XLR, Mono Jack) 0dBu nominal. +21dBu max.
Aux Outputs (Jack sockets) 0dBu nominal. +21dBu max.
Alt Outputs (phono sockets) 0dBu nominal. +21dBu max.
Rec Outputs (phono sockets) 0dBu nominal. +21dBu max.
- Frequency Response**
Mic in to Mix L/R Out, 30dB gain +0.5/-1dB 20Hz to 20kHz.
Line in to Mix L/R out 0dB gain +0.5/-1dB 10Hz to 30kHz
Stereo in to Mix L/R out +0.5/-1dB 10Hz to 30kHz
- THD+n**
Mic in to Mix L/R Out, 0dB gain 1kHz +10dBu out 0.004%
Mic in to Mix L/R Out, 30dB gain 1kHz 0.014%
Line in to Mix L/R out 0dB gain 0dBu 1kHz 0.005%
Stereo in to Mix L/R out 0dB gain +10dBu 1kHz 0.003%
- Headroom**
Analogue Headroom from nominal (0Vu) 21dB
USB in & out headroom from nominal (0Vu) 14dB
- USB Audio CODEC (Coder/Decoder)**
USB Audio In/Out USB 1.1 compliant 16bit.
Sample Rate 32, 44.1, or 48kHz
- Noise**
Mic Pre EIN @ max gain 150R input Z 22-22kHz -127dBu
Mix L/R out, L/R faders = 0, 22-22kHz -88dBu (ZED-14)
Mix L/R out, L/R faders = 0, 22-22kHz -84dBu (ZED-24)

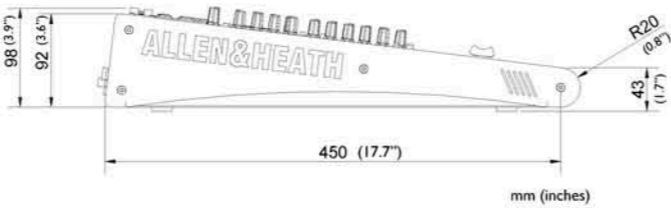
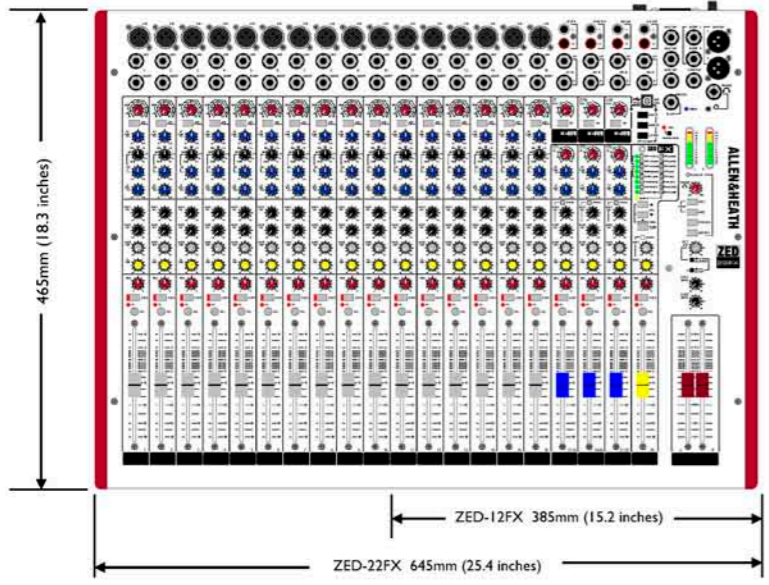

Weight		
	ZED-12FX	ZED-22FX
Unpacked	6.5kg (14.3 lb)	10.5kg (23.1 lb)
Packed	10.5kg (23.1 lb)	15kg (33 lb)

A rack mounting kit is available for ZED-12FX. The part number is: ZED1402-RK19



Two new mixers join Allen & Heath's ZED range, building on the innovative format with the addition of in-house designed pro-standard FX.

Leave the competition behind with stand out features such as 2-channel USB audio I/O, revolutionary Duo-Pre preamps, MusiQ 'British' EQ, dual stereo inputs, all in a professionally built package

ALLEN & HEATH
www.allen-heath.com/zed
sales@allen-heath.com
t:+44 (1326) 372070

Other ZEDs in range:
ZED-14, ZED-24 Stereo USB
ZED-420, ZED-428, ZED-436 4-bus USB



ZED-12FX



ZED-FX

Launched to complement the existing ZED series, the ZED FX has been developed around an FX chipset purely for the new model. Here at Allen & Heath, our DSP engineers have been working hard, crafting and refining beautiful reverb algorithms. The effects are available nowhere else - this quality and integration is only available from the ZED FX.

An essential selection of 16 time-delay effects have been designed with small groups in mind who don't want to carry around an effects unit with their gear but who still want great quality FX at their gigs and on their recordings.

ZED FX are easily controlled using 3 buttons and 17 LEDs. Quickly tap the ideal delay time or 'dial-in' the perfect amount of reverb on the lead vocal. One-stop navigation and editing... In fact, just as easy as your effects pedals. Hold down the TAP button and press the up or down button to alter the effects parameter, for example on patch (9) Plate, this would adjust the decay length.

The ZED FX is designed to fulfil all the functions a small band would need without their own sound engineer. The layout and features have been arranged to be logical and instantly recognisable at a dark gig- a mixer you can trust to perform.



DuoPre™

Based on the proven designs of our larger mixers, the pre-amp in the ZED uses a two stage design with carefully controlled gain in both stages. The microphone pre-amp uses both stages, whereas hotter line level signals enter at the second stage. This allows the individual sources to be treated separately (no pad), and match their specific gain and impedance demands. This also means that gain is more evenly distributed around the gain control, and keeps noise to a minimum.

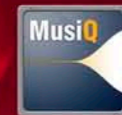

MusiQ

ZED-FX features a responsive 3-band, swept mid frequency design which utilises MusiQ with optimised slope (or Q factor) for equalising individual instruments.



USB audio flexibility

Fiddling around the back of your computer to get to the built-in soundcard? Wrong levels, buzzing, grainy thin sound...? It's a distant memory with the ZED! No longer must demos be compromised or complicated with the top quality integrated soundcard. The whole ZED range comes with a full duplex USB soundcard built-in, many useful routing options (including master LR pre and post, aux 1 & 2 mixes) and a separate stereo return channel.



Build quality

The ZED continues A&H's legacy of quality design and workmanship, even at this price-point. We have continued to use separate vertical PCB construction on the ZED borrowed from our large pro-audio mixers to keep the mixers sturdy and roadworthy. Even with the smallest ZED, every one of its controls is solidly PCB mounted, and every potentiometer is nutted to the front panel.



SONAR LE - provided Free!

We have included Sonar LE with our ZED range so you can start building up tracks and recording gigs immediately. It couldn't be more straightforward. Record from the ZED mixer via USB, and play back from Sonar through the mixer, to get arranging and creating at once! The combination of Sonar and ZED can also be used as an effects send- insert a plug-in into Sonar and let the computer become an effects unit.

ZED FX Features:

- DuoPre™ mic preamplifier
- 6 or 16 mono channels with insert point
- 3 dual stereo input channels
- Stereo USB soundcard built-in; 2 channels of I/O and 1 multi-function stereo return channel
- 16 custom designed FX built-in with tap tempo, and separate FX channel.
- 3 aux sends for monitors or FX
- 100mm professional quality faders
- MusiQ 3 band EQ with swept-mid band
- Extra ALT out for mix position monitor wedge

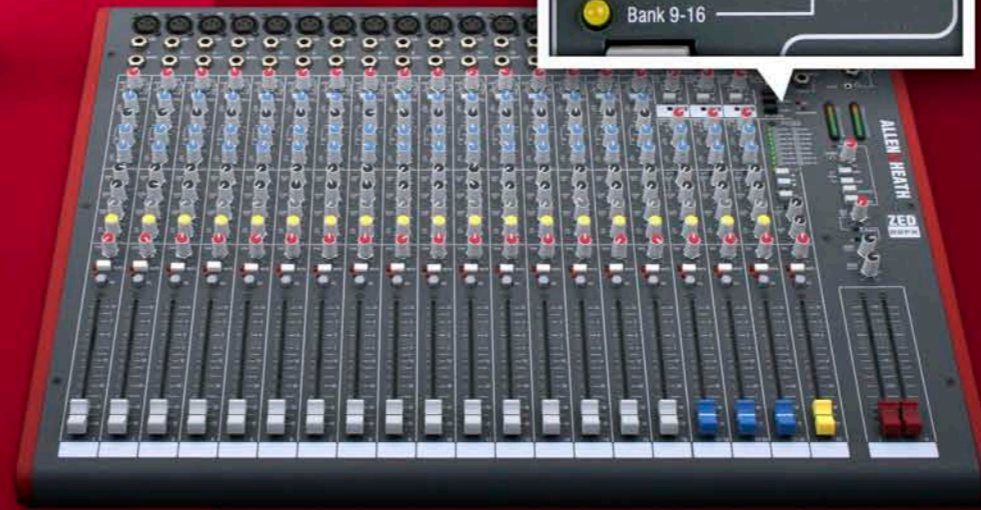

ZED-22FX