



Middle Atlantic Products, Inc.®

middleatlantic.com

# U Series/U317/UTR1 Rackshelves

EIA/TIA Compliant

## U Series / U317 / UTR1 Rackshelves

### Features

#### U Series - Universal rackshelves

- Available in 1 through 4 rackspaces
- Weight capacity from 35 to 85 lbs. depending on size
- Accommodates most standard non-rackmountable components
- See chart for part numbers and dimensions
- Contractor packs available
- UL Listed in the US and Canada

#### U317 - Vented 3 space rackshelf

- 17- 3/4" depth allows for deeper components
- 60 lb. weight capacity
- Vent pattern provides superior air circulation
- Slotted rear flange for cable management

#### UTR1 - Half / third rack shelf

- 25 lb. weight capacity
- Generous vent pattern provides superior air circulation
- Hook & loop strips included for mounting any half or third space components without hardware
- Contractor packs available



U2



U317

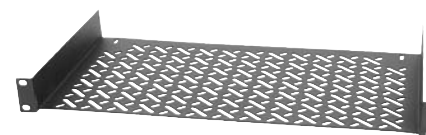

UTR1

### Architects' and Engineers' Specifications

#### U Series

Solid, one-piece 16-gauge steel rackshelf shall be Middle Atlantic Products model # U<sub>x</sub> (x = # of rackspaces, refer to chart). Weight capacity shall be \_\_\_ (refer to chart). Rackshelf shall feature durable flat black powder coat finish. Contractor packs shall be available with twelve U1 or six U2 rackshelves and shall be model # U1-RP12 or U2-RP6. U series rackshelf shall be warrantied to be free from defects in material or workmanship under normal use and conditions for the lifetime of the product. U series rackshelf shall be UL Listed in the US and Canada.

#### U317

Vented three rackspace rackshelf shall be Middle Atlantic Products model # U317. One-piece, 16-gauge rackshelf shall provide a 60 lb. weight capacity. U317 shall features slotted rear flange for cable management. Depth of 17-3/4" shall accommodate deeper components. U317 shall be warrantied to be free from defects in material or workmanship under normal use and conditions for the lifetime of the product.

#### UTR1

Half / third rack shelf with 10" depth shall be Middle Atlantic Products model # UTR1. Weight capacity shall be 25 lbs. UTR1 shall include two 2" x 10" hook & loop strips for component mounting and a generous vent pattern for superior air circulation. Contractor packs shall be available with twelve UTR1 rackshelves and shall be model # UTR1-RP12. UTR1 shall be warrantied to be free from defects in material or workmanship under normal use and conditions for the lifetime of the product.

electronic version available at [middleatlantic.com](http://middleatlantic.com)

## Engineered Mounting Solutions

US: New Jersey • California • Illinois • Voice: 973-839-1011 Fax: 973-839-1976 • [middleatlantic.com](http://middleatlantic.com)  
Canada: Ontario • British Columbia • Voice: 613-836-2501 Fax: 613-836-2690 • [middleatlantic.ca](http://middleatlantic.ca)

# U Series / U317 / UTR1 basic dimensions

## U Series

All dimensions in inches unless otherwise noted [Bracketed dimensions in millimeters]

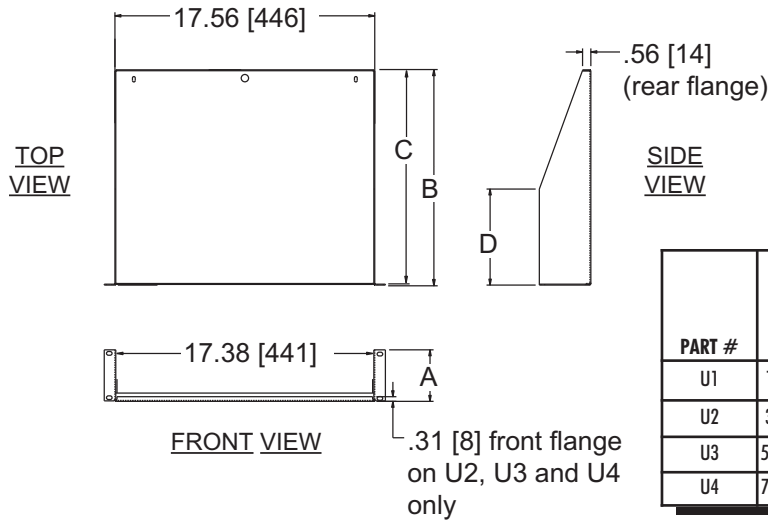

PART #	RACKING HEIGHT / RACKSPACES "A"	OVERALL DEPTH "B"	USEABLE DEPTH "C"	"D"	WEIGHT CAPACITY
U1	1.75 [44] (1 SP)	10.78 [274]	10.72 [272]	6.05 [154]	35 lbs. [16 kg]
U2	3.50 [89] (2 SP)	14.55 [370]	14.43 [367]	6.49 [165]	50 lbs. [23 kg]
U3	5.25 [133] (3 SP)	14.55 [370]	14.43 [367]	5.71 [145]	70 lbs. [32 kg]
U4	7.00 [178] (4 SP)	15.50 [394]	15.38 [391]	6.00 [152]	85 lbs. [39 kg]

## U317

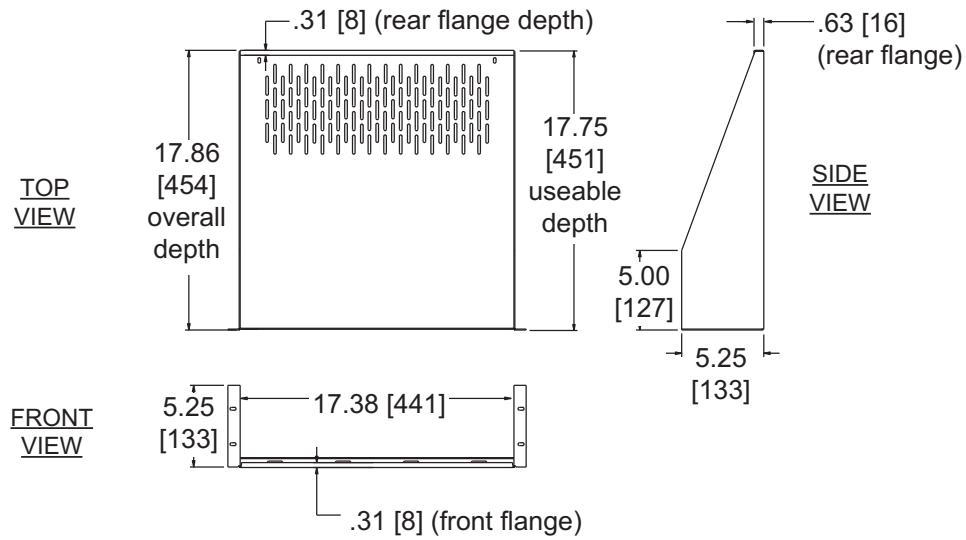

## UTR1

