

## SPECIFICATIONS

<b>Loudspeaker Type:</b>	3-way, horn loaded coaxial, weather-resistant
<b>Operating Range:</b>	90 Hz to 16 kHz 125 Hz to 12500 Hz (± 6 dB)
<b>Max Input Ratings:</b>	200W continuous, 500W program 35 volts RMS, 77 volts momentary peak
<b>Recommended Power Amplifier:</b>	420W to 600W @ 6 ohms
<b>Sensitivity (1W/1m):</b>	106 dB SPL (125 Hz to 10 kHz 1/3 octave bands) 107 dB SPL (250 Hz to 4 kHz speech range)
<b>Maximum Output:</b>	129 dB SPL / 136 dB SPL (peak)
<b>Nominal Impedance:</b>	6 ohms
<b>Minimum Impedance:</b>	3.2 ohms @ 11220 Hz
<b>Nominal -6dB Beamwidth:</b>	60° H (+32° / -17°, 2 kHz to 10 kHz) 40° V (+33° / -1°, 2 kHz to 10 kHz)
<b>Axial Q / DI:</b>	20.5 / 13.1, 2 kHz to 12.5 kHz
<b>Crossover Frequency:</b>	600 Hz / 4 kHz
<b>Recommended Signal Processing:</b>	70 Hz high pass filter
<b>Drivers:</b>	LF (1) 12" weather treated, Ferrofluid-cooled MF (1) M200, Ferrofluid-cooled HF (1) 1" exit, titanium free, Ferrofluid-cooled
<b>Driver Protection:</b>	None
<b>Input Connection:</b>	12 foot (4 m) SJOW #16 gauge
<b>Controls:</b>	None
<b>Enclosure:</b>	Rotomolded HDPE, light grey
<b>Mounting/Rigging Provisions:</b>	(5) 3/8-16 rigging points
<b>Grille:</b>	3-layer WeatherStop™ (Perforated steel, foam, stainless steel mesh)
<b>Required Accessories:</b>	None
<b>Supplied Accessories:</b>	(1) Stainless steel (304) yoke bracket (1) Aiming strap
<b>Optional Accessories:</b>	TRC400 transformer (400W 70/100/140V) Pole mount (ATM Flyware or Polar Focus) See <a href="http://www.atmflyware.com">www.atmflyware.com</a> or <a href="http://www.polarfocus.com">www.polarfocus.com</a>
<b>Dimensions—Height:</b>	16 inches (406.4 mm)
<b>Width:</b>	16 inches (406.4 mm)
<b>Depth:</b>	16.167 inches (411.15 mm)
<b>Weight:</b>	42.3 lbs (19.2 kg)
<b>Shipping Weight:</b>	49 lbs (22.2 kg)

### NOTES:

- Sensitivity: Free field pink noise measurement at 40 ft (12.2 m) at 60% power; extrapolated to 1 meter and an input of 2.45 volts RMS.
- Watts: All wattage figures are calculated using the rated nominal impedance.



## APPLICATIONS

- Primary loudspeakers for stadia and athletic fields
- Outdoor background music / paging systems
- Theme and amusement parks
- Fairgrounds, rodeos, air shows
- Malls, cruise ships, skating rinks
- Swimming pools
- Convention centers
- Portable sound systems
- Racetrack catch fence systems

## FEATURES

- Rotomolded, UV enclosure
- Pattern control down to 630 Hz
- High efficiency
- Integral mounting points
- High power passive crossover
- Five-year product warranty / Fifteen-year enclosure warranty

## DESCRIPTION

The R.5HP is a three-way horn loaded weather-resistant loudspeaker system engineered to provide maximum intelligibility from a most compact design. By the packaging of Community's well-known M200 midrange driver coaxially within the mouth of the 12" LF horn, an extremely powerful tool for voice announcement systems was created. High frequencies are handled by Community's non-metallic diaphragm UC1 1" exit HF driver. The M200/UC1 creates effortless voice-power with HF sparkle that must be heard to be appreciated. No longer do audiences need to experience the unpleasant sound of "honky" re-entrant paging horns. The R.5HP can act as both a musical entertainment loudspeaker and a voice PA loudspeaker simultaneously. Each system is backed by Community's five-year product warranty and fifteen-year enclosure warranty.

## FREQUENCY RESPONSE

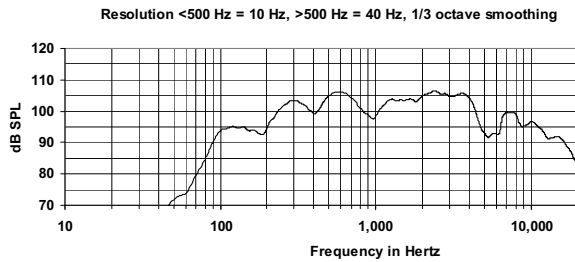

## IMPEDANCE

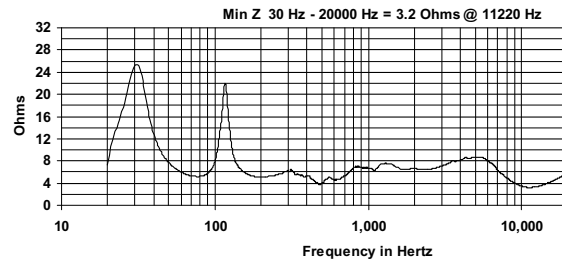

## BEAMWIDTH

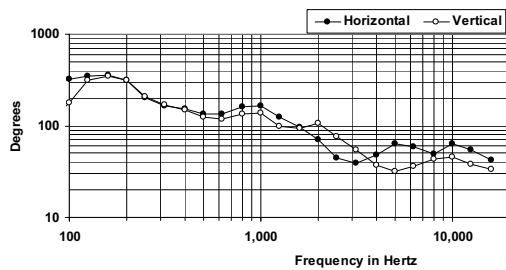

## AXIAL Q

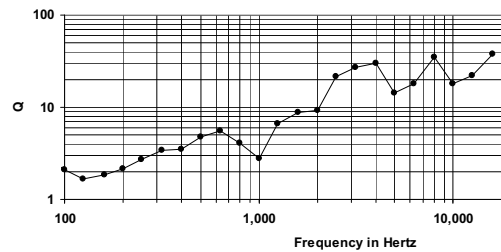

## DIMENSIONS

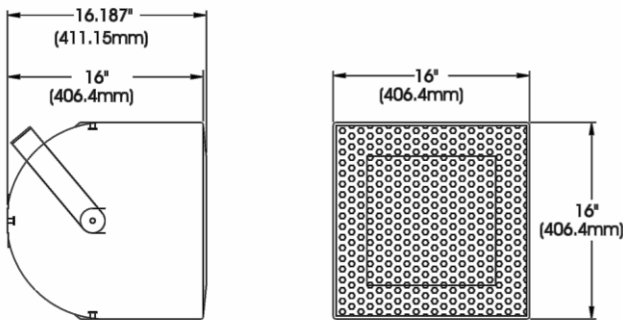

## R.5 YOKE

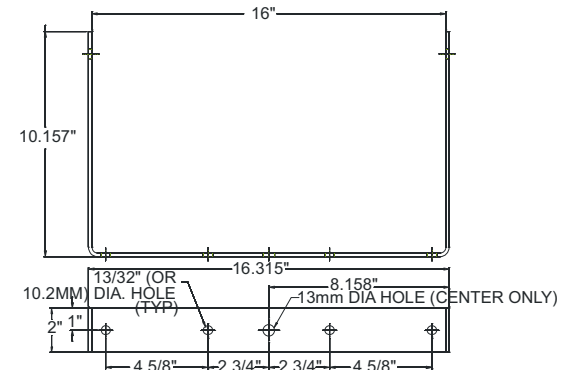

## ARCHITECTURAL SPECIFICATIONS

The loudspeaker system shall be a horn-loaded, three-way, coaxial design consisting of one 12" Ferrofluid-cooled driver, one M200 Ferrofluid-cooled compression driver, and one 1" exit compression driver mounted on a horn inside the cabinet. The drivers shall be connected to a passive crossover network with crossover frequencies at 600 Hz and 4 kHz respectively. The cabinet shall be a roto-molded polyethylene enclosure providing weather and UV resistance with three layer weather resistant grille. The input connection shall be one 12' (4m) SJOW #16 gauge cable with stripped ends. The enclosure shall incorporate five 3/8-16 rigging points for multiple mounting options. In addition, the loudspeaker will be supplied with one stainless steel yoke bracket. The loudspeaker system shall have an amplitude response of 125 Hz-12.5 kHz (+/- 6 dB SPL), an input capacity of 35V RMS, 107 dB SPL sensitivity @ 2.45V / 1 meter between 250Hz-4kHz at a nominal 6 ohm impedance. The nominal dispersion shall be 60° x 40° over a frequency range of 2 kHz to 10 kHz. The dimensions of the enclosure are defined as 16" x 16" x 16" (HWD) at a weight of 42.3 lbs.

Community strives to improve its products on a continual basis. Specifications are therefore subject to change without notice.