



Quam

BR8VP

Vandal Resistant, Round Loudspeaker Baffle

BS8VP

Vandal Resistant, Square Loudspeaker Baffle

0603 - VANDAL RESISTANT COMPONENTS

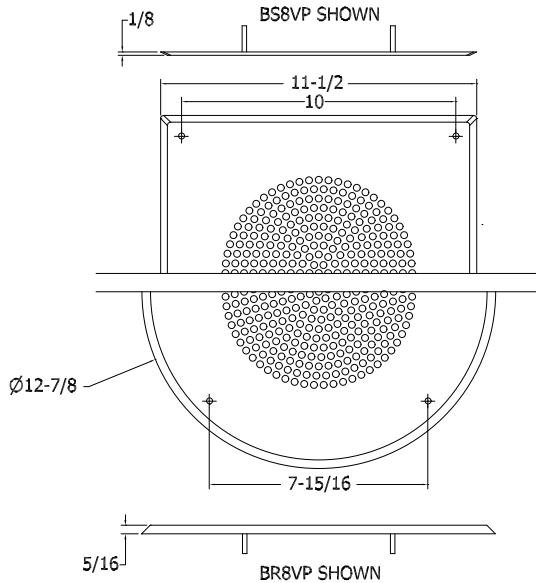

GENERAL DESCRIPTION

The Quam BR8VP is a 16 gage steel, round vandal-resistant loudspeaker baffle.

The Quam BS8VP is a 16 gage steel, square vandal-resistant loudspeaker baffle.

Both versions are supplied with a steel interwoven security screen to be mounted between the baffle and loudspeaker, 4 welded 8-32 x 1" studs on the back surface for speaker mounting and 4 8-32 x 1" 'pin-in-hex' mounting screws and tool.

Finish: White baked epoxy hybrid.

INTENDED USE

Indoor environment. For use with 8" frame loudspeakers and related components.

SYSTEM COMPONENTS

N/A

RECOMMENDED ADDITIONAL QUAM COMPONENTS

- 0104.4- Speaker, Transformer Assemblies
- 0201- Coaxial Loudspeakers, Individual
- 0202- Dual Voice Coil Loudspeakers, Individual
- 0203- Public Address Loudspeakers, Individual (Except 4C3PAB, 4C10PAB, 12C10PAXB)
- 0401- Flush Mounted Back Boxes
- 0402- Loudspeaker Mounting Devices (Except SSB-4, SSB-6, SSB-9)

Recommended construction sequences, installation instructions and A&E Specifications are available in various formats on the Quam Architects' and Engineers' Resources CD or on the web at: www.quamspeakers.com

CORRECTION / DETENTION

06

Quam-Nichols Company

234 East Marquette Road, Chicago, IL 60637
Phone: (800) NEED NOW Fax: (888) NEED NOW
(800) 633 - 3669 (888) 633 - 3669
E-Mail: neednow@qnc.com www.quamspeakers.com

