



Quam

SYSTEM 19

2' x 2' CLASS

UL LISTED, 2-Way, Full Range, 6-1/2" Woofer - 1" Dome Tweeter, 20W-70V Rotary Select Transformer with an 8 Ohm Position

GENERAL DESCRIPTION

The **SYSTEM 19** is a complete, UL Listed, 2-way, shallow depth, lightweight, 2' x 2' ceiling tile replacement loudspeaker system consisting of an 6-1/2" O.D. woofer, 1" dome tweeter, and a 20W-70V rotary select transformer with an 8 Ohm position. Molded fiber enclosure is 1,412 CID. Powder coated steel baffle with standard perforation and five (5) seismic tie-off points. The cable clamp is included. No assembly required.

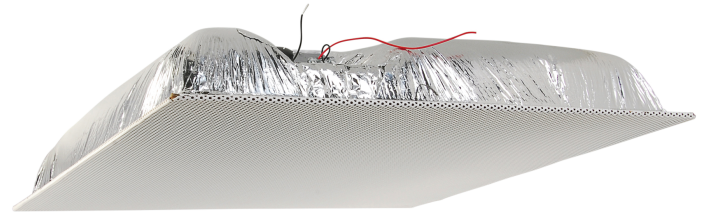

INTENDED USE - Indoor Environment

Program Material	Signal tones, voice, and music
UL LISTED 1480	As a General Signaling Device - When installed with supplied installation instructions and requirements of NEC /AHJ. (UEAY, UEAY7- Canada)
UL LISTED 2043	Suitable for use in air-handling spaces
City of Chicago Approved	Material and construction permits use where ceiling plenum is part of the air handling system.
Installation	Mounted parallel to floor plane in a 24" wide suspended ceiling tile grid.

AUDIO SPECIFICATIONS

Average Sensitivity	91 dB SPL, 1W/1M
Loudspeaker Power Rating	30W RMS EIA 426A Standard
Calculated Output	104 dB-SPL 20W/1M
Magnet Type & Weight	BeFe Ceramic, 10 oz. Nominal
Frequency Response	60 Hz - 20 kHz EIA 426A Standard
Nominal Coverage Angle	100° Included Angle -6 dB / 2 kHz, Half space
Audio Connection	12" Leads
Unit Weight	8.20 Lbs

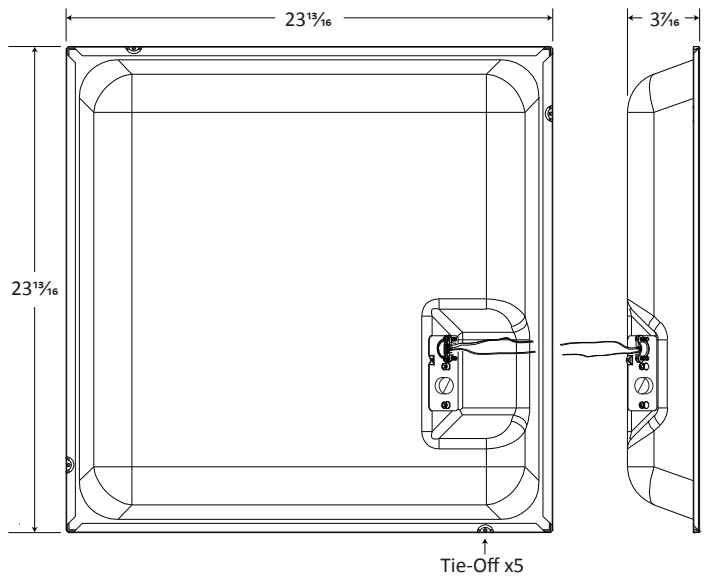

SYSTEM COMPONENTS

Loudspeakers	6-1/2" O.D. Woofer, 1" Dome Tweeter
Transformer	20W-70V : 5 Tap + 8 Ohm, Rotary Select (20W, 10W, 5W, 2.5W, 1.25W, 8 Ohm)

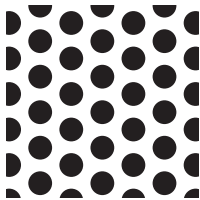

Standard Perforation Pattern
Shown as 1" Square Sample

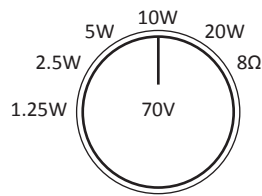

Speaker Tap Selector

Recommended construction sequences, installation instructions, and A&E Specifications are available in various formats in the QUAM Architects' and Engineers' Resources section on the web at: www.QuamSpeakers.com					QUAM-NICHOLS COMPANY, INC. 234 East Marquette Rd. Chicago, IL. 60637 Tel: 1-800-NEED-NOW (800-633-3669) Fax: 1-888-NEED-NOW (888-633-3669) e-mail: NeedNow@QNC.com www.QuamSpeakers.com
					© 2013 Quam-Nichols Company reserves the right to make changes and/or improvements to its products at any time and without notice.