

Technical Manual

JBL AM5212/26

PROFESSIONAL

SPECIFICATIONS

ACOUSTIC & ELECTRICAL SPECIFICATIONS:

- Nominal Impedance: 8 Ohms
- Transducer Power Rating (AES): LF: 400 W (1600 W peak), 2 hrs
300 W (1200 W peak), 100 hrs
HF: 40 W (160 W peak), 2 hrs
- Long-Term Power Rating (IEC): Passive mode: 300 W (1200 W peak), 100 hrs
- Frequency Response: 43 Hz - 18 kHz (± 3 dB)
- Frequency Range: 37 Hz - 20 kHz (-10 dB)
- Maximum SPL: Bi-amp mode: LF: 122 dB-SPL cont avg (128 dB peak)
HF: 129 dB-SPL cont avg (135 dB peak)
Passive mode: 121 dB-SPL cont avg (127 dB peak)
- System Sensitivity: Passive mode: 96 dB-SPL
1 watt @ 1 meter
- Crossover Frequency: 1.5 kHz

SYSTEM COMPONENTS:

- Cabinet: Enclosure (Not For Sale)
- Grille: 338163-007

SYSTEM COMPONENTS: (cont'd)

- Low Frequency Driver: JBL 262H-1, 300 mm (12 in) driver with 50.8 mm (2 in) dual voice coil
- DC Resistance: 5.5 ohm \pm 10%
- High Frequency Driver: JBL 2408H-1, 38 mm (1.5 in) exit compression driver, 38 mm (1.5 in) voice coil
- DC Resistance: 4.80 ohm \pm 0.2 ohm
- Crossover Network: 443800-001

AURAL SWEEP TEST SPECIFICATIONS:

- A. System Aural Sweep Test: 7.0Vrms Input, 10 Hz to 10 kHz
- B. M.F. Aural Sweep Test: 7.0Vrms Input, 10 Hz to 1 kHz
- C. H.F. Aural Sweep Test: 0.75V Input, 200 Hz to 1.5 kHz

PHYSICAL SPECIFICATIONS:

- Enclosure Dimensions: 713 x 371 x 458 mm D (28.06 x 14.6 x 18.1 in.D.)
- Net Weight: 45 lb (20.2 kg.)

WARRANTY INFORMATION:

- Refer to Warranty Statement packed with each product.

PACKAGE

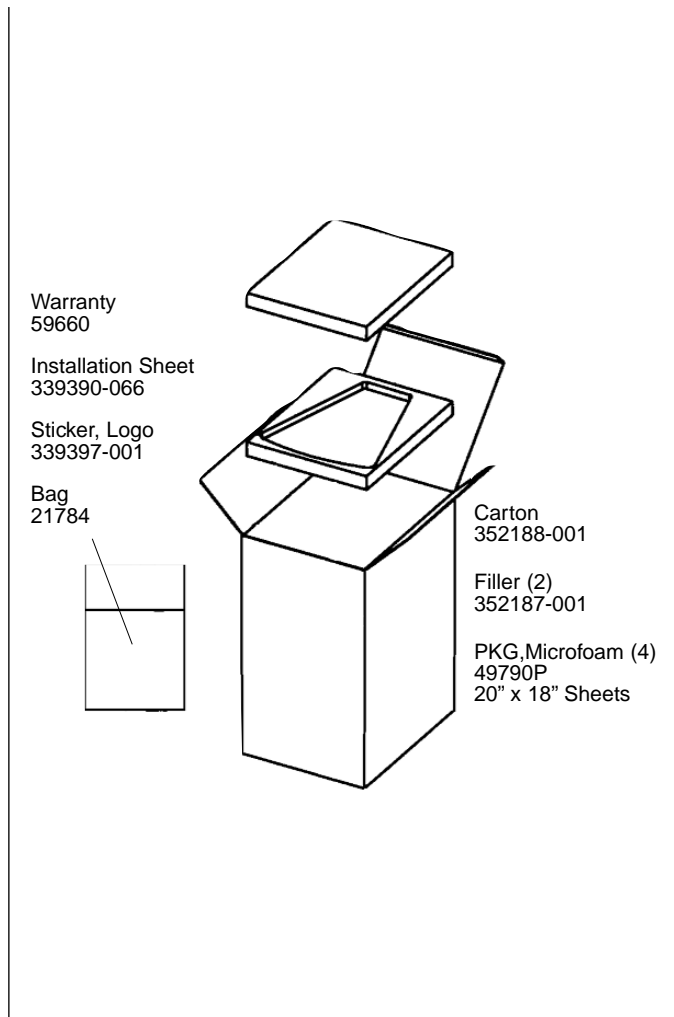

WIRING DIAGRAM

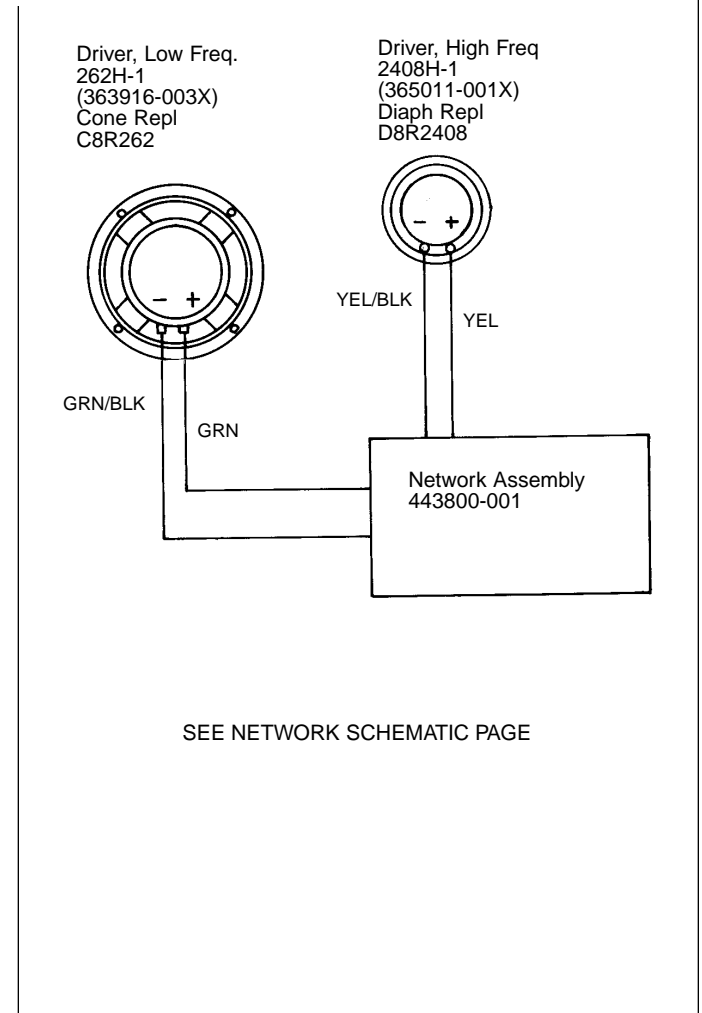

JBL AM5212/26 REV A

JBL AM5212/26

SCHEMATIC (443800-001)

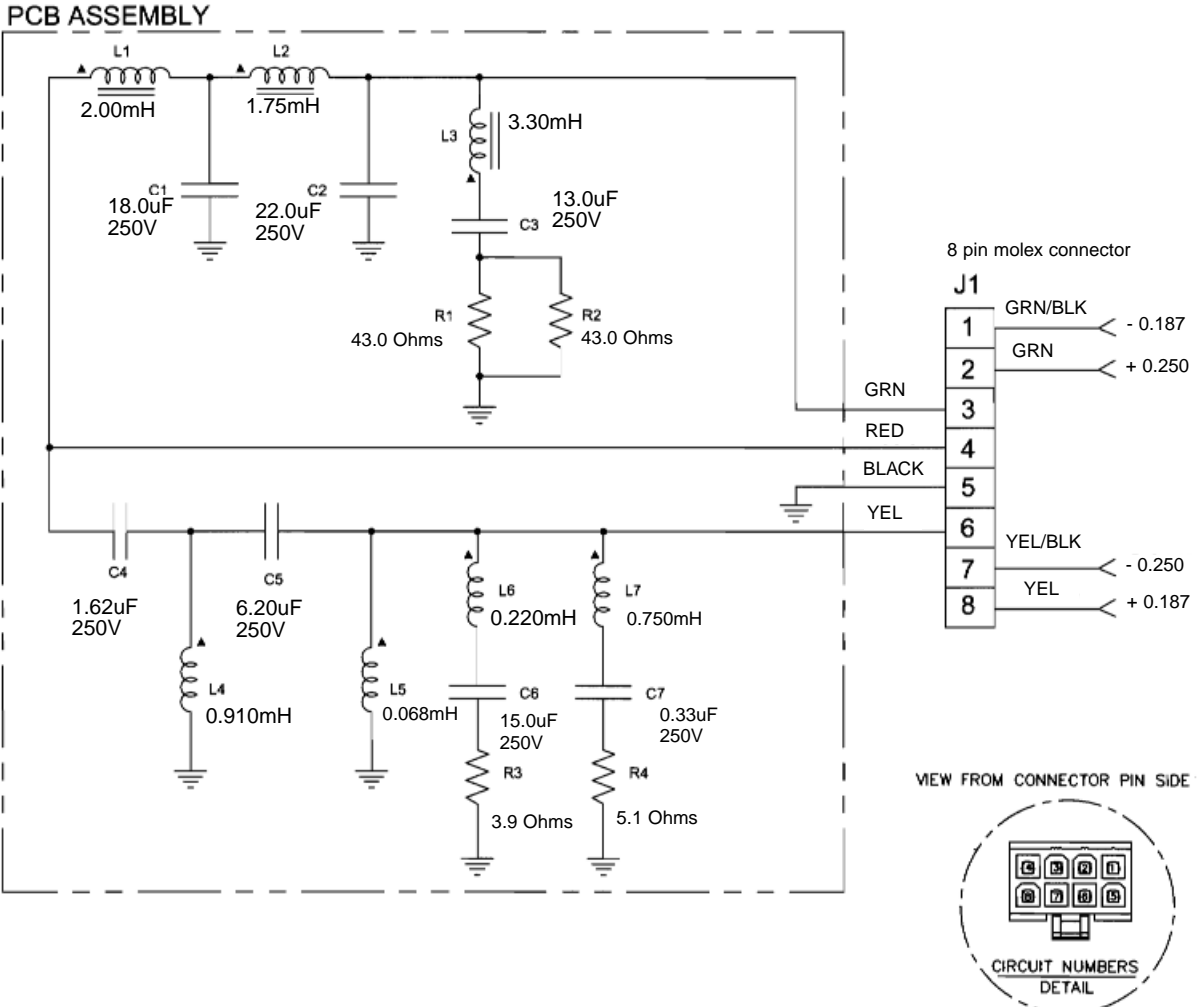

Individual Parts for the above crossover are not available.
 A complete replacement assembly should be ordered.

JBL AM5212/26

JBL AM5212/26

COMPONENT EXPLODED VIEW

