

Technical Manual

JBL AM5215/95



SPECIFICATIONS

ACOUSTIC & ELECTRICAL SPECIFICATIONS:

- Nominal Impedance: 8 Ohms
- Transducer Power Rating (AES):
 - LF: 500 W (2000 W peak), 2 hrs
 - 350 W (1400 W peak), 100 hrs
 - HF: 40 W (160 W peak), 2 hrs
- Long-Term Power Rating (IEC):
 - Passive mode: 350 W (1400 W peak), 100 hrs
- Frequency Response: 41 Hz - 18 kHz (± 3 dB)
- Frequency Range: 35 Hz - 20 kHz (-10 dB)
- Maximum SPL:
 - Bi-amp mode:
 - LF: 125 dB-SPL cont avg (131 dB peak)
 - HF: 129 dB-SPL cont avg (135 dB peak)
 - Passive mode: 124 dB-SPL cont avg (130 dB peak)
- System Sensitivity:
 - Passive mode: 98 dB SPL
 - 1 watt @ 1 meter
- Crossover Frequency: 1.8 kHz

SYSTEM COMPONENTS:

- Cabinet: Enclosure (Not For Sale)
- Grille: 338163-002

SYSTEM COMPONENTS: (cont'd)

- Low Frequency Driver: JBL 265H-1, 380 mm (15 in) driver with 50.8 mm (2 in) dual voice coil 5.25 ohm $\pm 10\%$
- DC Resistance: 5.25 ohm $\pm 10\%$
- High Frequency Driver: JBL 2408H-1, 38 mm (1.5 in) exit compression driver, 38 mm (1.5 in) voice coil
- DC Resistance: 4.80 ohm ± 0.2 ohm
- Crossover Network: 443677-001

AURAL SWEEP TEST SPECIFICATIONS:

- A. System Aural Sweep Test: 7.0Vrms Input, 10 Hz to 10 kHz Sweep Duration: 5 seconds
- B. L.F. Aural Sweep Test: 15.5V Input, 30 Hz to 1 kHz
- C. H.F. Aural Sweep Test: 0.75V Input, 200 Hz to 1.5 kHz

PHYSICAL SPECIFICATIONS:

- Enclosure Dimensions: 783 x 422 x 504 mm D (30.8 x 16.6 x 19.85 in.D.)
- Net Weight: 55 lb (25.0 kg.)

WARRANTY INFORMATION:

- Refer to Warranty Statement packed with each product.

PACKAGE

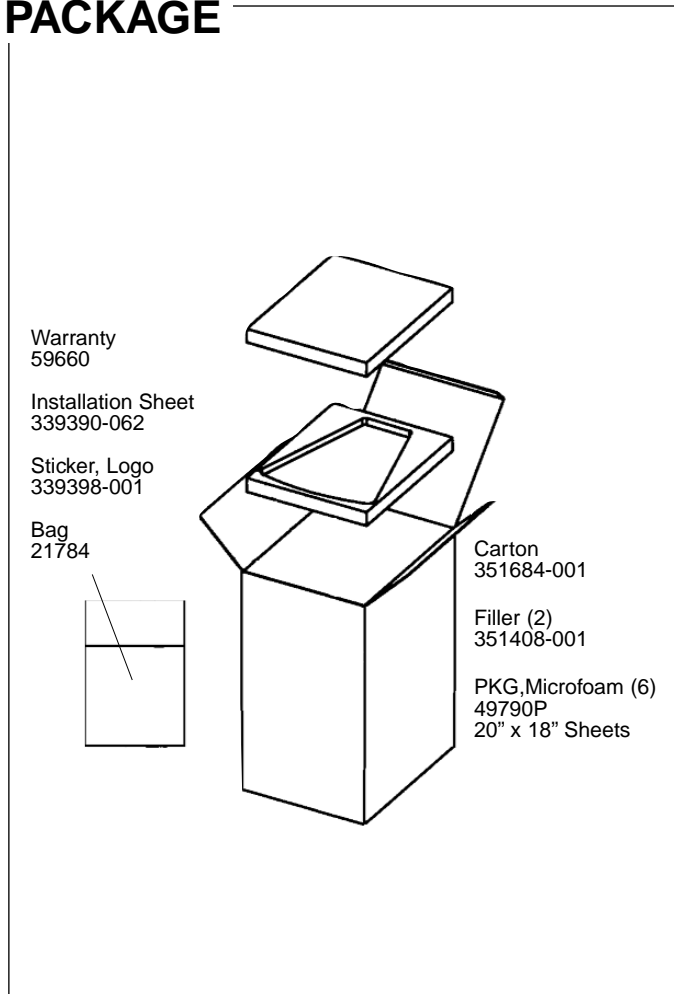

WIRING DIAGRAM

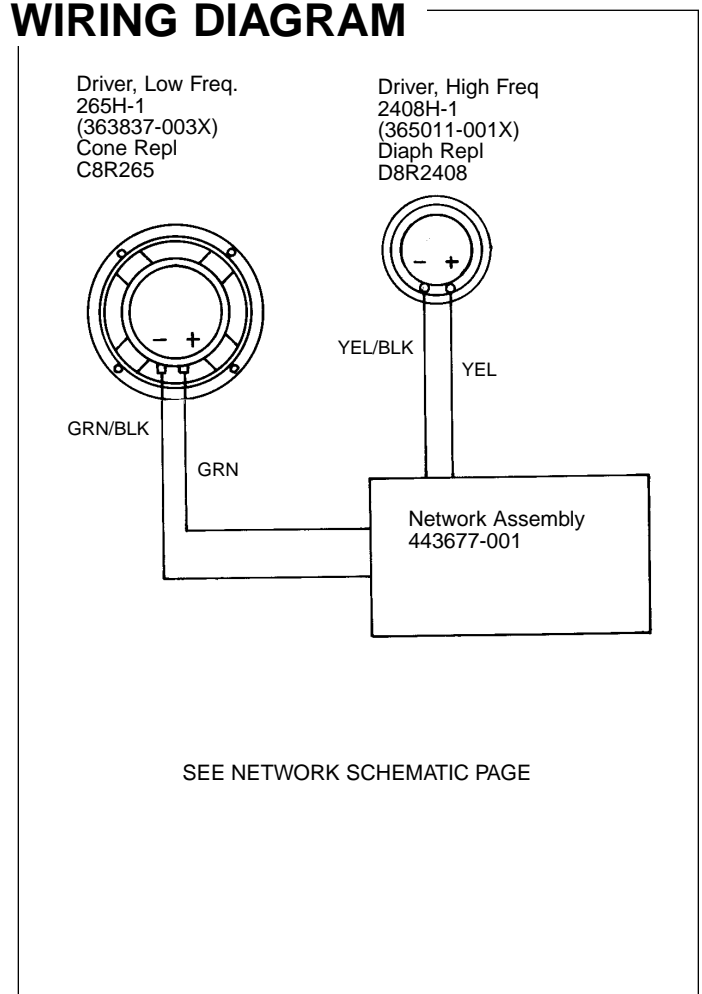

JBL AM5215/95

SCHEMATIC (443677-001)

VIEW FROM CONNECTOR PIN SIDE

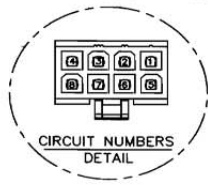

PCB ASSEMBLY

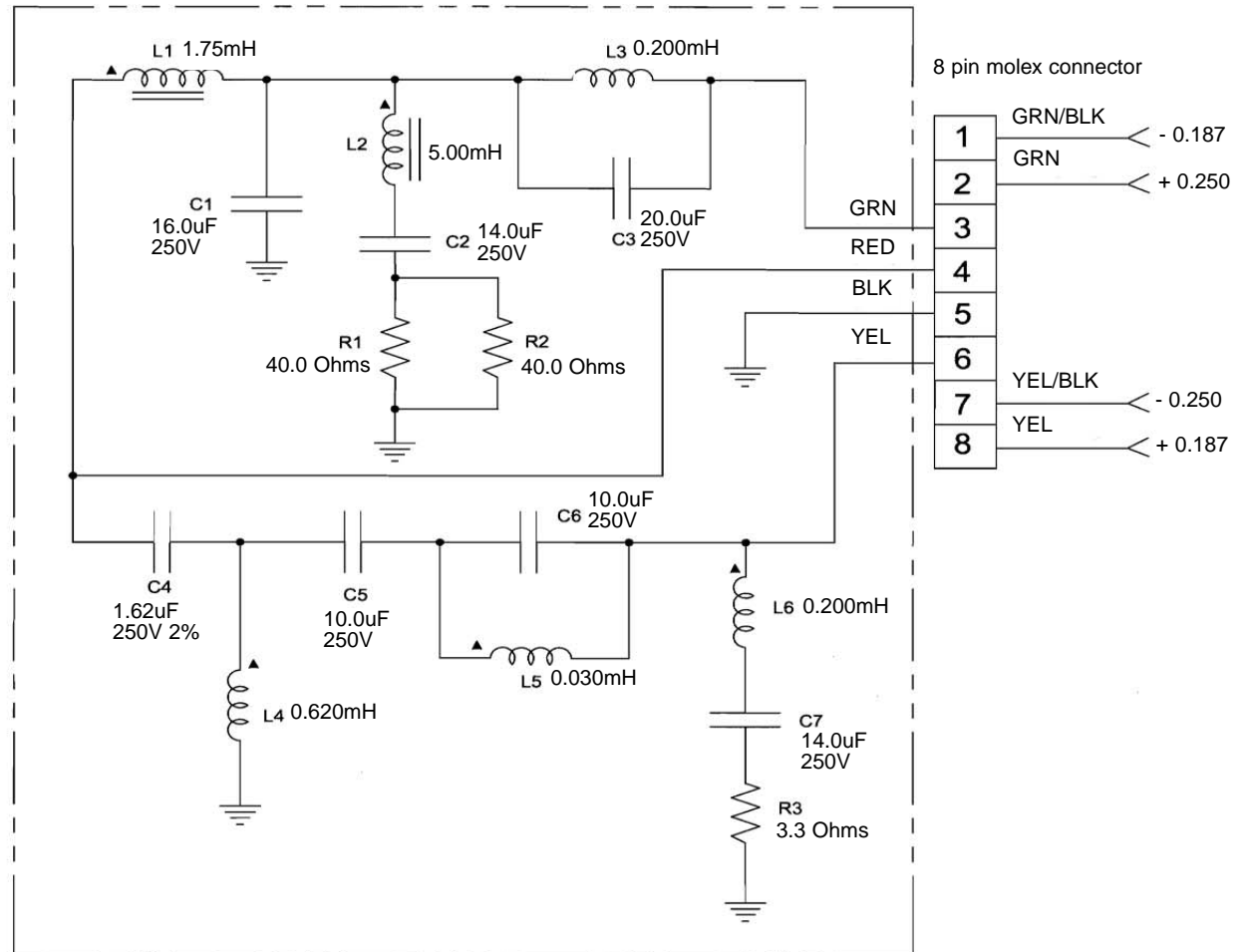

Individual Parts for the above crossover are not available.
A complete replacement assembly should be ordered.

JBL AM5215/95

JBL AM5215/95

COMPONENT EXPLODED VIEW

