

INSTRUCTION SHEET  
**DWR SERIES**  
DWR-FKxx FAN KIT

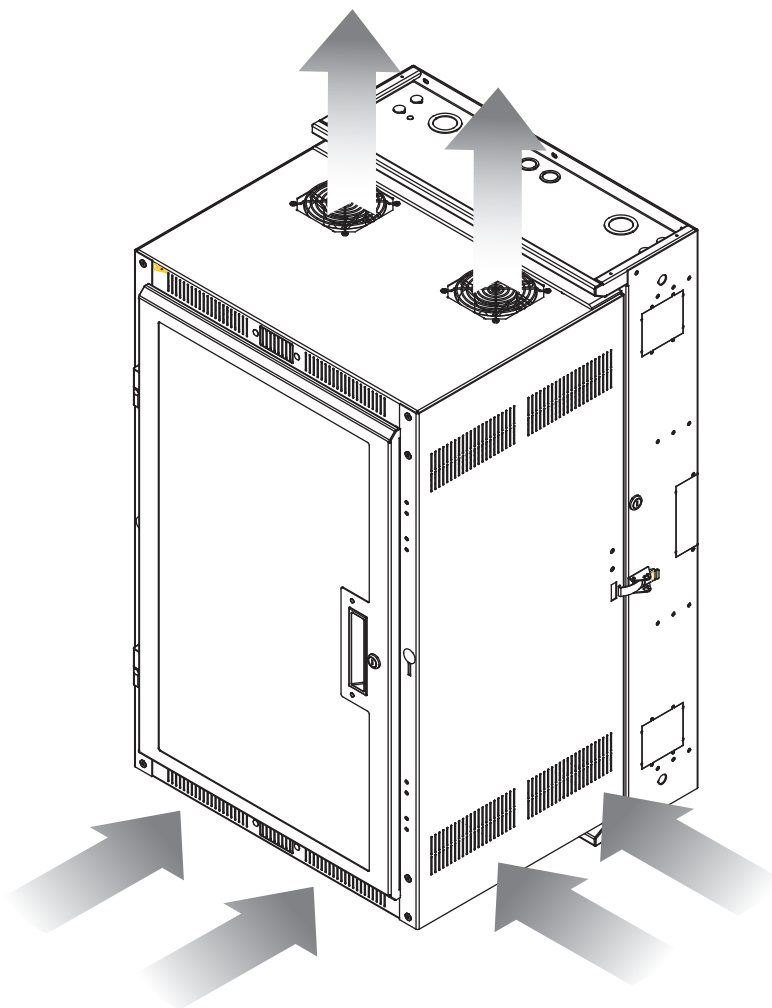

**DWR-FK CONTENTS**

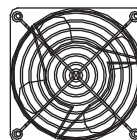

Two fans and four guards with hardware and power cord



Vent Blocker Kit

**THANK YOU**

Thank you for purchasing the DWR Series DWR-FKxx. Please read these instructions thoroughly before installing / assembling this product.

**PRODUCT FEATURES**

- Extend equipment life by removing excess heat
- Vent blockers provided to control airflow

**HARDWARE**

**FAN**

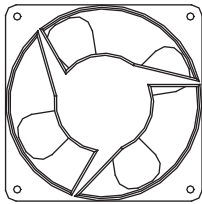

**QTY**  
2

**PART #**  
A

**FAN GUARD NUT**



**QTY**  
8

**PART #**  
C

**FAN GUARD**

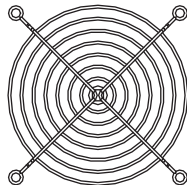

**QTY**  
4

**PART #**  
B

**FAN GUARD SCREW**



**QTY**  
8

**PART #**  
D

**POWER CORD**

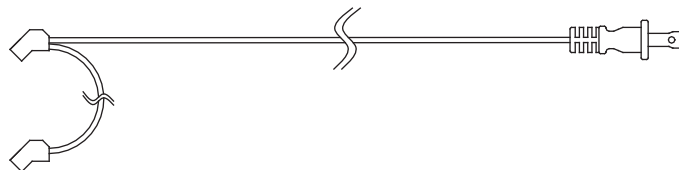

**QTY**  
1

**PART #**  
E

**SIDE VENT BLOCKER**



**QTY**  
2

**PART #**  
F

**FRONT VENT BLOCKER**



**QTY**  
2

**PART #**  
G

**DECORA® VENT BLOCKER**



**QTY**  
1

**PART #**  
H

## INSTALLATION

### INSTALLATION NOTES:

- Arrow on side of Fan (A) denotes air flow direction. Install with arrow pointing to top of enclosure. (FIGURE A)

- Install Fans with plugs facing each other as shown. This will ensure Power Cord (E) is able to reach both fans. (FIGURE B)

1) Install Fan (A), Guard (B) and hardware (C & D) as shown. (FIGURE C)

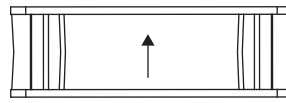

FIGURE A

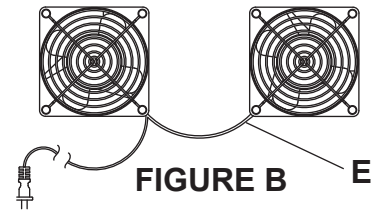

FIGURE B

E

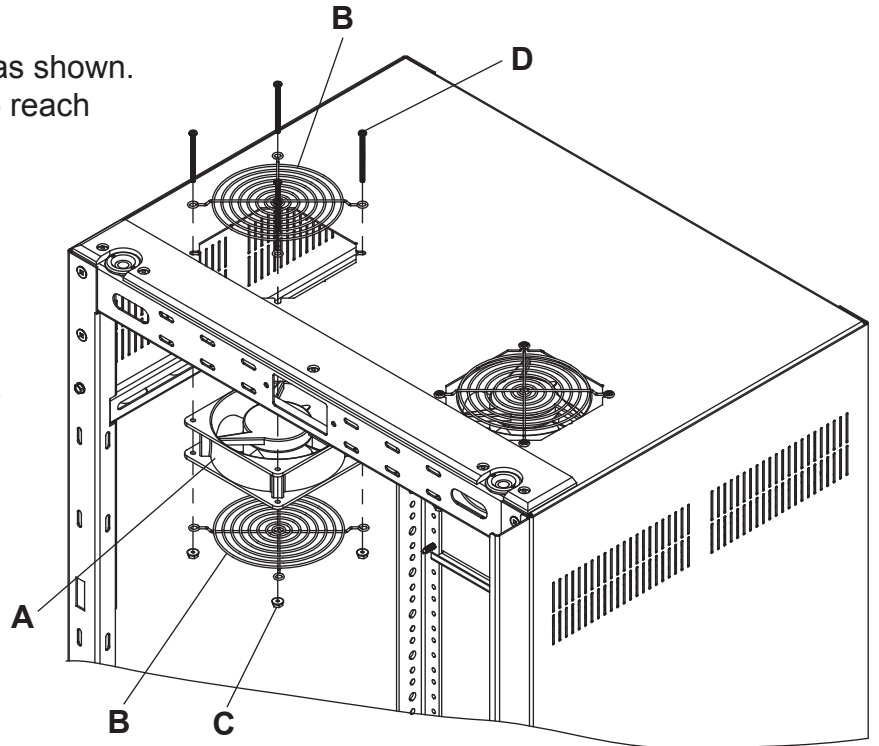

FIGURE C

(Rear view inside of DWR)

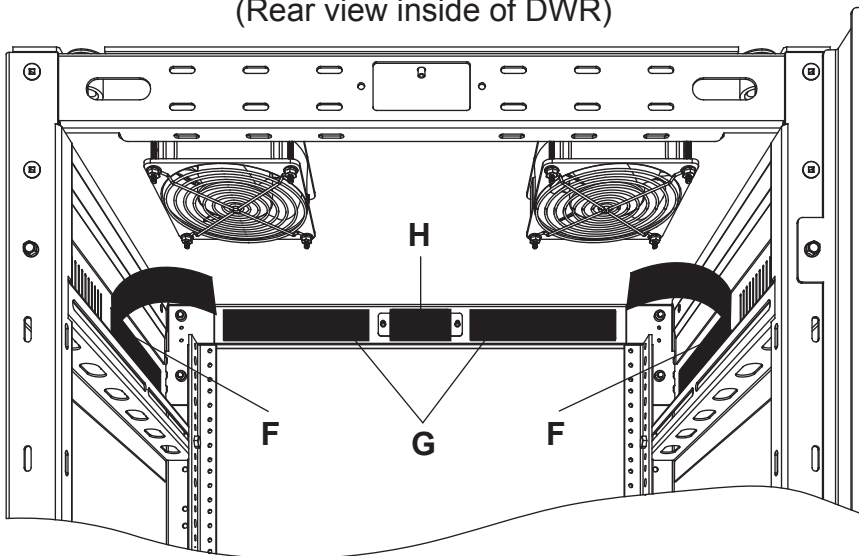

FIGURE D

2) Install Vent Blockers (F, G & H) as shown. (FIGURE D)

## **WARRANTY**

Middle Atlantic Products (the "Company") warrants the DWR-FKxx to be free from defects in material or workmanship under normal use and conditions for a period of (3) years from date of shipment by the Company.

The Company's entire liability to the purchaser, and the purchaser's (or any other party's) sole and exclusive remedy, under this warranty shall be limited, at the Company's option, to either (a) return of and refund of the price paid for, or (b) repair or replacement at the Company's factory of the products purchased, or any part or parts thereof, which the Company has determined to be defective after inspection thereof at the Company's factory.

This warranty does not cover damage due to acts of God, accident, misuse, abuse or negligence by parties other than the Company, or any modification or alteration of the products. In addition, this warranty does not cover damage due to improper handling, assembly, installation or maintenance.

THIS WARRANTY IS IN LIEU OF ALL OTHER WARRANTIES OF ANY KIND, EITHER EXPRESSED OR IMPLIED, INCLUDING, BUT NOT LIMITED TO, IMPLIED WARRANTIES OF MERCHANTABILITY AND FITNESS FOR A PARTICULAR PURPOSE.

TO THE MAXIMUM EXTENT PERMITTED BY APPLICABLE LAW, IN NO EVENT SHALL THE COMPANY BE LIABLE FOR ANY SPECIAL, INCIDENTAL, INDIRECT, OR CONSEQUENTIAL DAMAGES WHATSOEVER (INCLUDING, WITHOUT LIMITATION, DAMAGES FOR LOSS OF BUSINESS PROFITS, BUSINESS INTERRUPTION OR ANY OTHER PECUNIARY LOSS) ARISING OUT OF THE USE OF THE PRODUCTS PURCHASED, EVEN IF THE COMPANY HAS BEEN ADVISED OF THE POSSIBILITY OF SUCH DAMAGES. THE COMPANY'S LIABILITY TO THE PURCHASER (OR ANY OTHER PARTY) HEREUNDER, IF ANY, SHALL IN NO EVENT EXCEED THE PURCHASE PRICE OF THE PRODUCTS PAID TO THE COMPANY.

### **Corporate Headquarters**

Corporate Voice 973-839-1011 - Fax 973-839-1976  
International Voice +1 973-839-8821 - Fax +1 973-839-4982  
middleatlantic.com - info@middleatlantic.com

### **Middle Atlantic Canada**

Voice 613-836-2501 - Fax 613-836-2690  
middleatlantic.ca - customerservicecanada@middleatlantic.ca

### **Factory Distribution**

USA: NJ - CA - IL Canada: ON - BC

**At Middle Atlantic Products we are always listening. Your comments are welcome.**

**Middle Atlantic Products is an ISO 9001 and ISO 14001 Registered Company.**

