

IMPEDANCE SELECTION-
RECEPTACLE END OF MICROPHONE
FIGURE 1

GENERAL

The UNIDYNE® III Model 545SD is a dual-impedance, unidirectional, dynamic microphone. Shipped connected for low-impedance operation, it features a silent magnetic reed on/off switch.

The UNIDYNE III is a favorite for instrument pickup and recording, and can be used on lecterns for public address systems such as those used in political conventions and legislatures, convention halls, hotels, public auditoriums, stadiums, schools, and churches.

FEATURES

- Exceptionally uniform cardioid pattern minimizes feedback in PA applications
- Selectable dual-impedance operation
- Silent magnetic reed on/off switch with lock option
- Cardioid dynamic
- Frequency response: 50 to 15,000 Hz

CONNECTIONS

When using the microphone with a balanced input, pins 2 and 3 are the audio signal carriers. When using the microphone with an unbalanced input, use a cable wired with pin 2 as the signal carrier and pin 3 connected to the cable shield (ground), such as the Shure C20HZ high-impedance cable.

IMPEDANCE SELECTION

The microphone is shipped connected for low impedance operation. To change to high impedance, proceed as follows (refer to Figure 1):

1. Remove plug element at receptacle end of microphone by turning slotted setscrew in (counterclockwise) and carefully withdrawing plug element from case.
2. Disconnect 2-terminal impedance selection socket from rear of plug element.
3. Reconnect 2-terminal impedance selection socket in reverse position so that pin 3 of plug element is inserted in socket terminal "H" (White).
4. Reassemble plug element into microphone and seal setscrew securely by turning out (clockwise).

POLARITY

All cables and microphones should be tested to ensure that they have the same polarity. To test two microphones and/or their cables for proper polarity, connect them to an amplifier and talk or sing into them while holding them three or four inches apart. The sound from the speakers should be the same when talking into either microphone or directly between them. If the sound drops drastically, or if a dead spot is found when talking between the two microphones, either the microphones or their cables have opposite polarity.

To change the polarity of a microphone cable, either use a Shure A15PRS phase reverser or interchange the wires connected to pins 2 and 3 of the three-pin connector at one end of the cable. To change the polarity of a microphone, the microphone cartridge leads must be interchanged. This should be performed by your dealer, the Shure Factory Service Department, or other qualified service personnel.

SPECIFICATIONS

Type

Dynamic

Frequency Response

50 to 15,000 Hz (see Figure 2)

Polar Pattern

Cardioid (unidirectional)-uniform with frequency, symmetrical about axis (see Figure 3)

Impedance

Dual. Microphone rating impedance is 150 ohms (250 ohms actual) for connection to microphone inputs rated at 19 to 300 ohms and "High" for connection to high-impedance microphone inputs.

Wired for low impedance as supplied. To change impedance, see sections on Impedance Selection and Connections.

Output Level (at 1,000 Hz)

	"L"	"H"
Open Circuit Voltage*	-58.0 dB (1.3 mV)	-35.0 dB (17.6 mV)

*0 dB = 1 volt per Pascal (1 Pa = 94 dB SPL)

Polarity

Positive pressure on diaphragm produces positive voltage on pin 2 (with respect to pin 3). See Figure 4.

Switch

Built-in magnetic reed on/off switch with lockplate. To lock switch in the ON position, remove screw on lockplate and turn lockplate 180°. Reassemble and tighten screw.

Cartridge Shock Mount

Internal rubber vibration-isolator

Swivel Adapter

Positive action, adjustable through 90° from vertical to horizontal, permits easy removal for handheld use, suitable for mounting on stand with 5/8"-27 thread

Case

Chrome-plated die casting with ARMO-DUR® grille and stainless steel screen

Dimensions

See Figure 5

Net Weight (less cable)

255 grams (9 oz)

CERTIFICATION

Eligible to bear CE Marking. Conforms to European EMC Directive 89/336/EEC. Meets applicable tests and performance criteria in European Standard EN55103 (1996) parts 1 and 2, for residential (E1) and light industrial (E2) environments.

FURNISHED ACCESSORY

Swivel AdapterA25D

REPLACEMENT PARTS

Cartridge R45
 Plug Element..... RK169P
 Screen and GrilleRPM210

OPTIONAL ACCESSORIES

Line Matching Transformer.....A95 Series
 Desk StandS37A, S39A
 Isolation Mount..... A55M
 Dual Mount..... A26M
 Windscreen A2WS-GRA
 Cable, LO-Z (7.6 m [25 ft])..... C25J
 Cable, HI-Z (6.1 m [20 ft])..... C20HZ

ARCHITECTS' SPECIFICATIONS

The microphone shall be a moving coil (dynamic) type with a frequency response of 50 to 15,000 Hz. The unit shall have a cardioid polar characteristic. The cancellation at the sides shall be approximately 6 dB, and the cancellation at the rear shall be 15 to 20 dB. The microphone shall be dual impedance with a rated impedance of 150 ohms for connection to microphone inputs rated at 19 to 300 ohms and "High" for connection to high-impedance microphone inputs. Impedance change shall be solderless at the microphone connector.

The microphone output shall be:

Low Impedance-58.0 dB
 (0 dB = 1 volt per Pascal)
 High Impedance-35.0 dB
 (0 dB = 1 volt per Pascal)

The microphone shall have an XLR, three-pin professional audio connector and shall be equipped with a magnetic reed On-Off switch.

The microphone shall be provided with a swivel adapter, adjustable through 90° from vertical to horizontal, and suitable for mounting on a stand having a 5/8"-27 thread.

The overall dimensions of the microphone shall be 157 mm (6-3/16 in.) in length and 31.9 mm (1 1/4 in.) in diameter.

The microphone shall be the Shure Model 545SD-LC or equivalent.

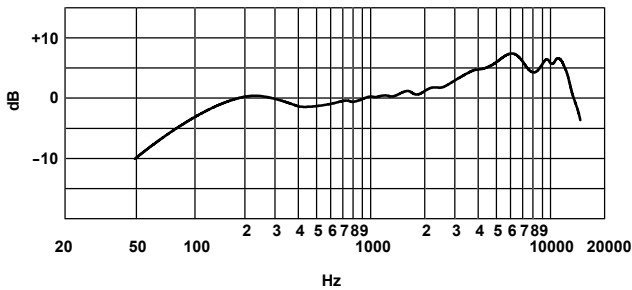

TYPICAL FREQUENCY RESPONSE
FIGURE 2

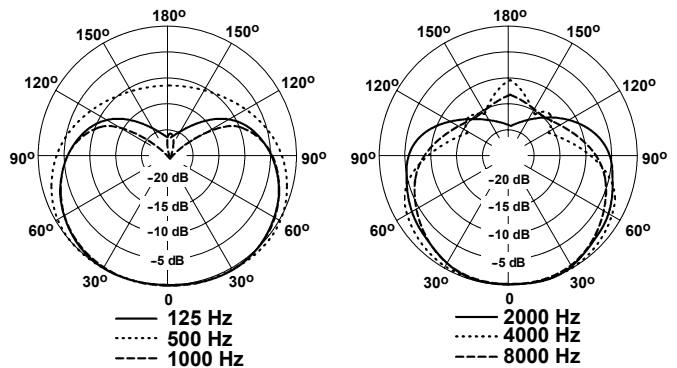

TYPICAL POLAR PATTERNS
FIGURE 3

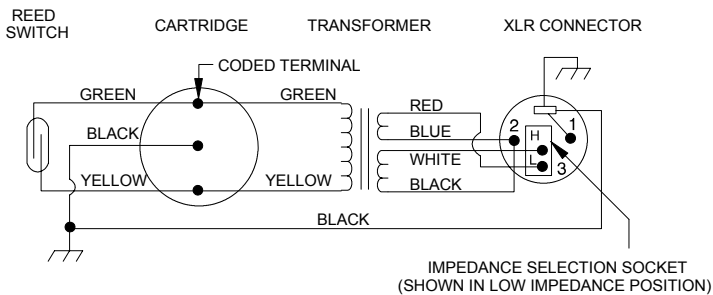

INTERNAL CONNECTIONS
FIGURE 4

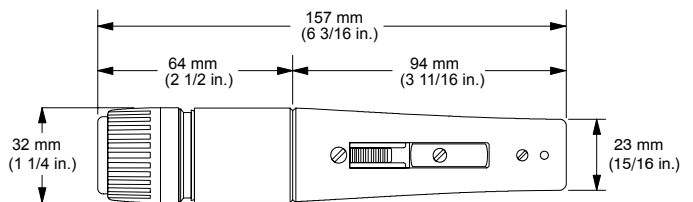

OVERALL DIMENSIONS
FIGURE 5