

PMB-1RR and PMB-2RR Pole-Mount Brackets

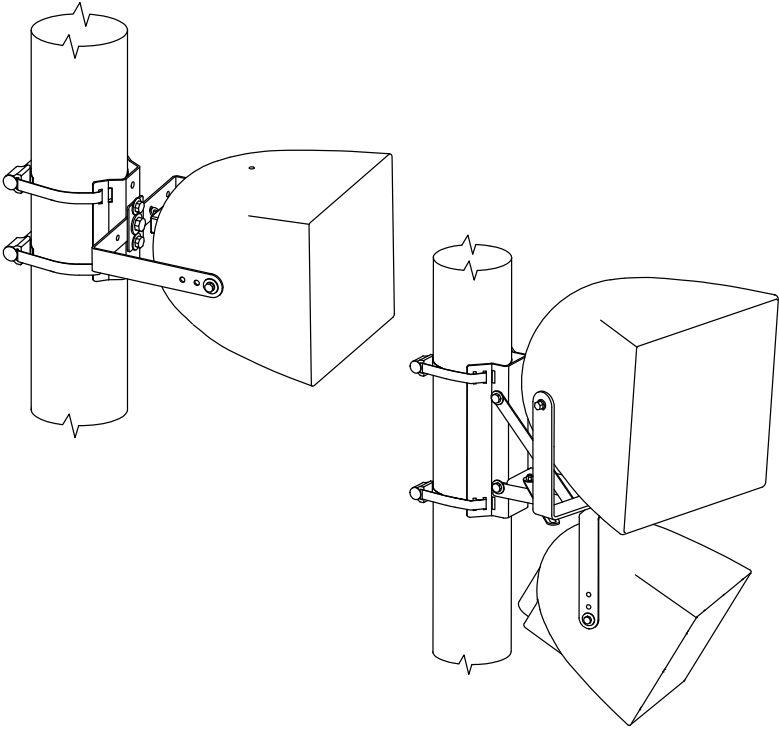

Instruction Guide



IMPORTANT SAFETY INFORMATION

Always follow these basic safety precautions when installing and using Community Model PMB-1RR and PMB-2RR Pole-Mount Brackets:

1. Read these instructions.
2. Keep these instructions.
3. Heed all warnings.
4. Wear safety eyewear.
5. Follow all instructions, particularly those pertaining to mounting.
6. Only use accessories that are specified and approved by the manufacturer.
7. As a backup to the main mount, we highly recommend using an additional PMB-1RR as a safety mount. Refer to page 9 in this guide.
8. Inspect all components regularly, as required by local conditions and regulations.



The PMB-1RR and PMB-2RR Pole-mount Bracket Kits are suitable for outdoor use and non-corrosive atmosphere indoor applications.

APPROVED USAGE OF POLE-MOUNT BRACKETS

The PMB-1RR and PMB-2RR pole-mount brackets must only be used with Community Loudspeakers and only the following model loudspeakers:

R.15COAX, R.25, R.35COAX, R.35-3896, R.5, R.5HP, R.5COAX, R.5SUB, R.5MAX, RMG200A, W2-218, W2-228, and the W2-2W8.

The PMB-1RR is designed to mount one Community loudspeaker.

The PMB-2RR is designed to mount up to two Community loudspeakers.

As a backup to the main mount, use of an additional PMB-1RR as a safety mount is highly recommended.



CAUTION: Installation of loudspeakers should be performed only by trained and qualified personnel. It is strongly recommended that a licensed and certified professional structural engineer approve the mounting design.

High Wind Load Usage

The "working load limit" and "safety factor" ratings for the PMB-1RR and PMB-2RR are provided for static (unchanging) vertical (downward) loads only. These ratings do not apply to forces in any direction other than vertical (downward) and they do not apply to dynamic (rapidly changing) loads.

Storms or other high wind conditions can produce high dynamic (rapidly changing) loads on loudspeakers and brackets suspended outdoors. These wind-caused loads may be in any direction, not just in the vertical (downward) direction. Thus, for installations in areas that may experience high winds, the "Working Load Limit" and "Safety Factor" for the PMB-1RR and PMB-2RR must be derated appropriately. To calculate an appropriately derated Working Load Limit and Safety Factor, Community recommends retaining the services of a licensed structural engineer familiar with wind conditions at the installation site. Community can provide EPA (effective projected area) and other product information to aid the structural engineer in making these calculations.

About this manual: Due to ongoing technical advances, changes or modifications may have occurred that are not covered in this publication. The latest version of this manual and the most recent product information published by Community is always available at <http://www.communitypro.com>.

TOOLS AND MATERIALS REQUIRED

TOOLS:

- Lineman's pliers
- Metric (10 mm – 19 mm) & SAE socket set
- Metric box wrench set
- Metric and SAE Allen Key Set
- Sheet metal shears
- Tape measure
- Marking pen
- 8 ft. (2.5m) light-duty rope or ratcheting strap

MATERIALS:

- Safety Cable Materials (See page 8)
- Banding material sufficient for the size of the pole; .75" x .032" (19 mm x 0.81 mm) 201 stainless steel banding is recommended.
- Community PMB-BAND kit contains 92" (2.3m) of Banding. Use BAND100 FT for multiple installations.

UNPACK AND INSPECT

PMB-1RR	Qty
BAND CLAMP	4
POLE MOUNT PLATE	1
CLAMP PLATE	1
SAFETY FITTING	2
M10x35 HEX HEAD BOLT	2
M10 OVAL LOCK NUT	2
M12x35 HEX HEAD BOLT	1
M12 OVAL LOCK NUT	1
M10x150 FULL THREAD CARRIAGE BOLT W/NUT	2
10 mm EXTERNAL TOOTH LOCK WASHER	4
10 mm FLAT WASHER	8
12 mm FLAT WASHER	2
M8 OVAL LOCK NUT	2
8 mm FLAT WASHER	2
M8 STUD	2
3/8-16 STUD	2
3/8-16 HEX NUT	2
8 mm LOCK WASHER	2

PMB-2RR	Qty
BAND CLAMP	4
POLE MOUNT PLATE	1
ARM	1
SUPPORT STRAPS	2
LOCKING STRAPS	2
M10x25 HEX HEAD BOLT	6
M10 OVAL LOCK NUT	6
M12x45 HEX HEAD BOLT	1
M12 OVAL LOCK NUT	1
M10x150 FULL THREAD CARRIAGE BOLT W/NUT	2
10 mm EXTERNAL TOOTH LOCK WASHER	2
10 mm FLAT WASHER	8
12 mm FLAT WASHER	2
M8x20 HEX HEAD BOLT	4
M8 OVAL LOCK NUT	4
8 mm FLAT WASHER	8
10 mm SPLIT LOCK WASHER	6

WAIVER OF LIABILITY

Whenever Community Light and Sound, Inc. (CLS), dba Community Professional Loudspeakers is requested to provide advice or material regarding the design or installation of its equipment such advice or material is intended and provided for information purposes only. The advice or material is only intended to familiarize the user with various options for design, coverage and installation. User expressly agrees that CLS shall not be liable for any damages, whether in tort, contract, strict liability or otherwise consequential, incidental or otherwise to person or property as a result, directly or indirectly, of the use of any advice or material. The user of any advice or material provided by CLS assumes all risk and liability for the use thereof. Without limitation to the above, CLS does not accept liability or responsibility for the performance of any manufacturer, design, method, use, material or technique employed by the acoustic designer and/or installation company. All advice, information or material is subject to field variations and environmental conditions. All advice, information, or material given is offered on the assumption that common or standard practices for installation used in the construction trades is applied to all phases of the user's project. Actual assembly or configuration must be performed only by persons with knowledge of mechanical trades and rigging, where applicable. Any installation method must be certified by a Professional Engineer licensed in the state in which assembly or configuration is located.

ASSEMBLE THE PMB-1RR MOUNT AND CABINET YOKE

Read all instructions before assembly. Some operations can be performed on the ground.

1. Assemble the pole-mount plate, the loudspeaker cabinet mounting bracket, and the clamp plate, and attach using the hardware provided, as shown in the figure.
2. Tighten each bolt and nut securely at this time with the recommended tools. These components will not need to be adjusted during installation.

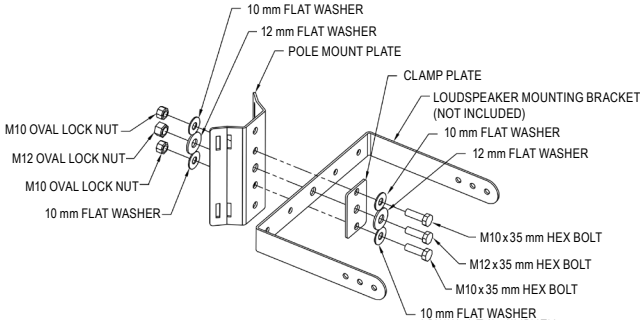

WARNING: Be careful not to over or under tighten fasteners. Sufficient torque must be applied to ensure a secure assembly. Over tightening can lead to damaged fasteners thus weakening the component(s). Either scenario can lead to risk of assembly separation leading to injury, death, or property damage.

To complete installation of the PMB-1RR, refer to page 7, "ASSEMBLE THE BANDS AND ATTACH THE MOUNT".

ASSEMBLE THE PMB-2RR MOUNT AND CABINET YOKE(S)

1. Attach the arm to the pole-mount plate using the hardware provided.
2. Do not fully tighten any nuts until the unit is fully assembled.
3. Attach the support straps to the arm, and fully tighten all nuts with recommended tools.

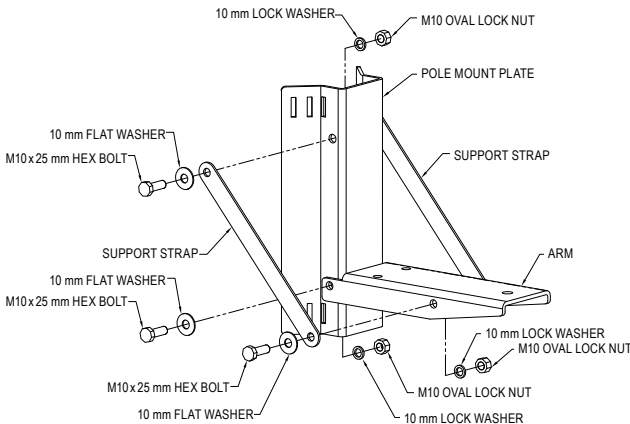

WARNING: Be careful not to over or under tighten fasteners. Sufficient torque must be applied to ensure a secure assembly. Over tightening can lead to damaged fasteners thus weakening the component(s). Either scenario can lead to risk of assembly separation leading to injury, death, or property damage.

ASSEMBLE YOKE(S) AND ATTACH TO MOUNT

1. Attach the yoke with the M12 hardware provided.
2. Attach the locking straps with the M8 hardware provided.
3. Ensure that the yokes and straps have appropriate clearance before final assembly to permit loudspeaker cabinet aiming.
4. If the loudspeaker includes an aiming strap, consult the appropriate Owner's Manual for instruction on how to attach the aiming strap.

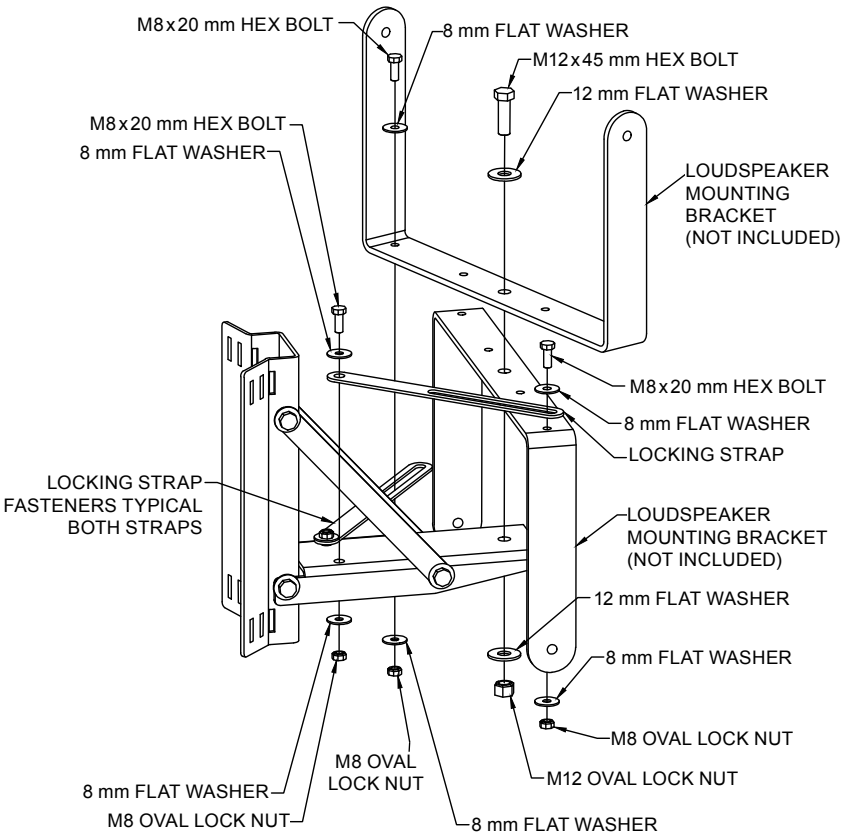

ASSEMBLE THE BANDS AND ATTACH THE MOUNT

Temporarily attach mount to pole

1. Position the pole-mount in the desired location on the pole.
2. Using a rope or ratchet strap, attach the mount firmly to the pole.

Measure, cut, and install bands

1. Measure the circumference of the pole where the bracket will be mounted. If the pole is tapered, be sure to adapt the band lengths to fit.

Note: When measuring the diameter of the pole, be sure to measure at the position where the pole-mount bracket will be attached. Many poles taper with height.

2. Measure the circumference of the pole, plus 12" (306 mm) for attaching the clamp ends.
3. Mark and cut banding in a comfortable working environment.
4. Repeat steps two and three to mark and cut additional pieces of banding, two bands for each bracket.
5. Measure and mark the cut lengths of banding at 5" (127 mm) from each end, and mark the point in the middle of the banding.
6. Feed the banding pieces through the slots in the pole bracket appropriate for the diameter pole. Banding should not have any sharp bends. Position the band so the middle mark is centered on the middle of the bracket.

Note: Banding may be doubled for extra strength in holding the mount to the pole. (Cut and use two pieces at each length).

7. The clamps provided with the Community banding kits will accept two lengths of banding.

Add clamp ends to bands

1. Slide one band clamp end onto each end of the banding piece. Position the angled edge to face away from the pole-mount.
2. Wrap the banding around the clamp end at the 5" (127 mm) mark. When the clamp is tightened, the end of the band will be held in place against the pole.
3. Bend the band and the clamp to a 90° angle, as shown in the drawing. This will make installation easier by positioning the parts to align easily with the carriage bolt at final assembly.
4. Repeat steps one through three for the remaining bands.

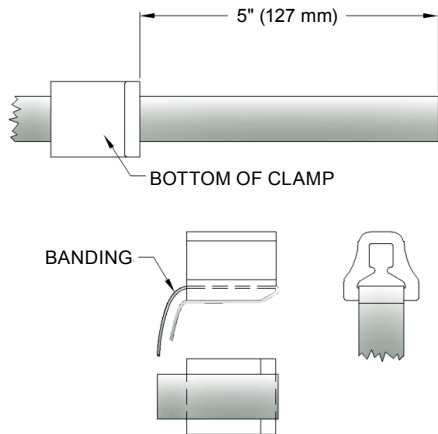

ATTACH MOUNT TO POLE

1. Attach the band clamps around the pole as shown, using the carriage bolt, flat washer, lock washer, and hex nut provided. When fully tightened, the clamps should be at least 3/8" (10 mm) apart.
2. Remove the ratchet strap or rope used to hold the mount temporarily to the pole.



WARNING: Be careful not to over or under tighten fasteners. Sufficient torque must be applied to ensure a secure assembly. Over tightening can lead to damaged fasteners thus weakening the component(s). Either scenario can lead to risk of assembly separation leading to injury, death, or property damage.

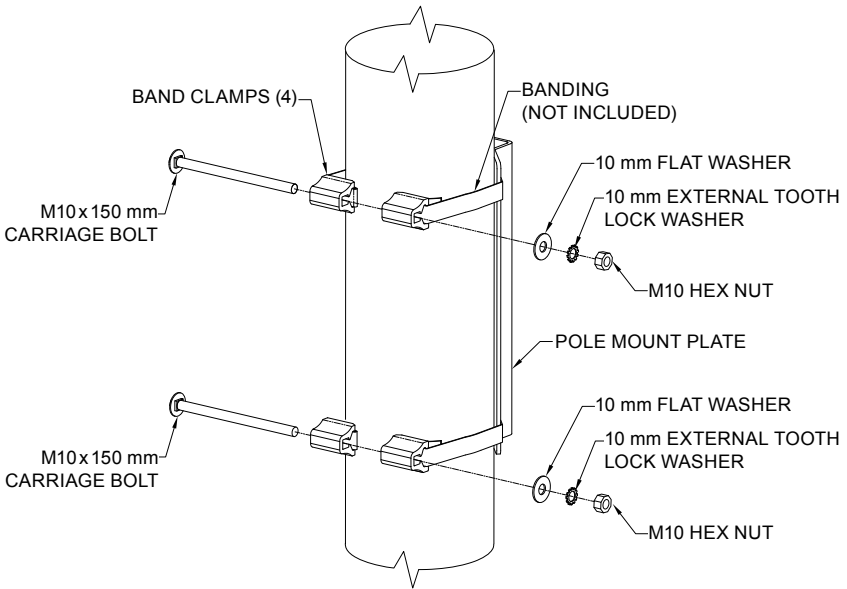

INSTALL SAFETY CABLE FITTING IN LOUDSPEAKER CABINET

NOTES:

- (R.25 and R.5) Install the safety cable fitting on each cabinet in the same manner with either pole-mount bracket.
- (R.15 and R.35) No additional fitting is necessary - the safety cable attachment loop is integrated into rear of the cabinet.
- (R.25 and R.5) If an extreme cabinet angle blocks the hole at the rear of the cabinet, install the stud in the closest available threaded hole to minimize the potential dynamic load if the mount fails.
- For WET II Series cabinets, another safety cable attachment point on the cabinet should be devised. A custom product order with appropriate rigging fittings may be necessary.

1. Thread the stud into the selected hole to a depth of 3/8" (9.5 mm).
2. Position the safety cable fitting on the stud as shown, with the cable hole pointing up after installation.
3. Attach the fitting using the supplied hardware. Fully tighten the hex nut.
4. The loudspeaker cabinet is now ready to be attached to the safety cable.

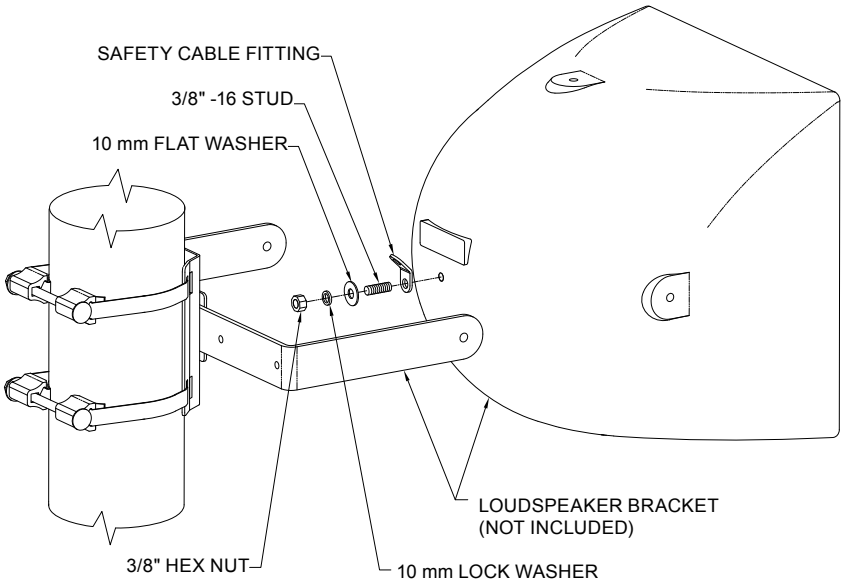

NOTE: Hardware shown should be used for all R.5 model loudspeakers. Use the following included hardware to attach the safety cable fitting to the R.25 models: M8 mm stud, safety cable fitting, 8 mm flat washer, 8 mm lock nut. No extra fitting hardware is necessary for the R.15 and R.35, see detail below. For other models, the installer must use suitable safety attachment hardware and method.

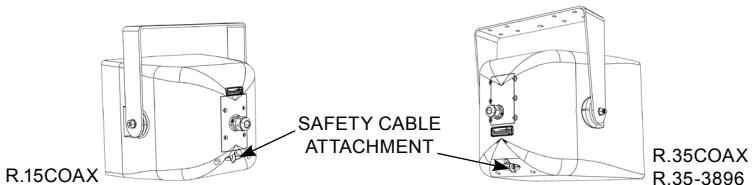

INSTALL PMB-1RR AS MOUNT FOR SAFETY CABLE

Complete installation, aim the cabinets as required, and tighten the yoke bolts, aiming straps (supplied with R-Series cabinets), and locking straps, before installing the safety cable.

Assemble safety cable mount and install safety cable

1. Assemble a PMB-1RR mount, and install it approximately one foot above the safety cable fitting of the uppermost loudspeaker cabinet.
2. Attach one safety cable per cabinet. See diagram for attaching safety cable. *Be sure the safety cable is taut, with minimal obstruction.*
3. Choose hardware and cables rated for the expected loads.
4. Refer to the specification sheet for specific working load limits. Specification sheet and technical drawings are available at www.communitypro.com.

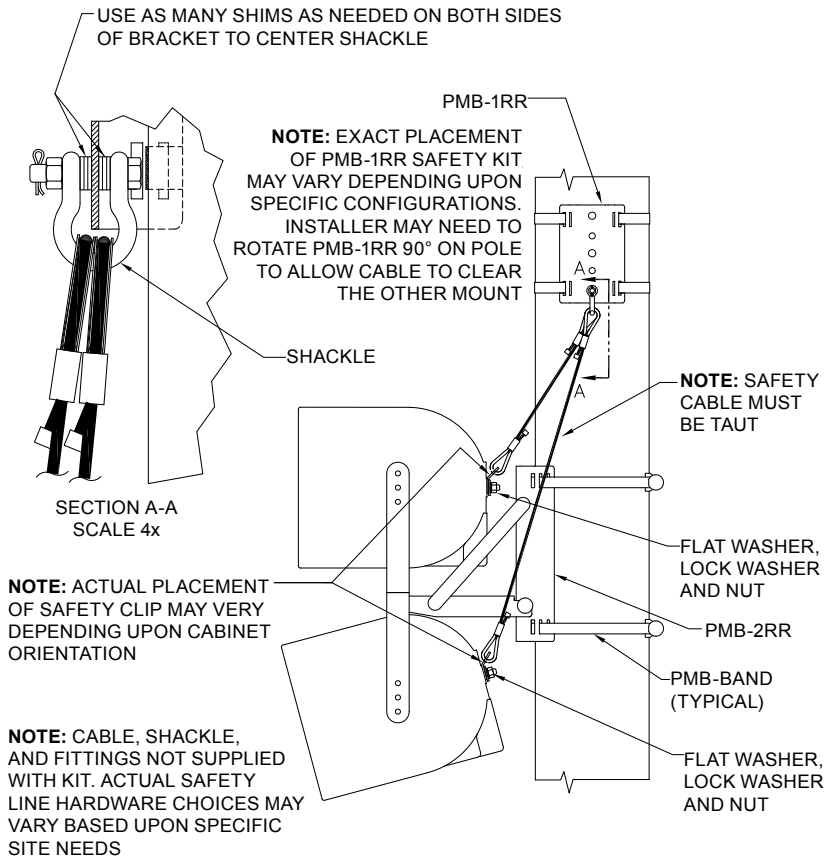

CAUTION: This figure only shows one example of one type of safety cable assembly. This is not intended to fully detail the correct practices of safety cable application. The cable assembly shown represents a steel wire rope type material, but other materials may be more appropriate such as chains. Actual choice of material for the safety cable assembly to be made by the installer and approved by the project P.E. Actual method of attachment and hardware may vary depending on work load conditions, continuous outdoor exposure, harsh environments, seismic conditions, and local regulations. Eye-nut or hoist-ring may be installed in center hole of PMB-1RR pole-mount plate to accommodate safety cable attachment.

LOUDSPEAKER DOWNTILT AND PAN CLEARANCE

IMPORTANT NOTE: When two loudspeakers are mounted on a PMB-2RR in top-bottom configuration and are panned to the left and/or right at different pan angles, the vertical downtilt of the top loudspeaker may be limited by interference from the position of the U-shaped mounting yoke of the lower loudspeaker. All configurations are shown with standard U-shaped mounting brackets or yokes.

PMB-1RR

SIDE VIEW: Vertical downtilt capability of all loudspeakers is 90°

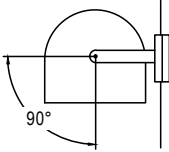

PMB-2RR

TOP VIEW: Left-to-right panning capability of single loudspeaker

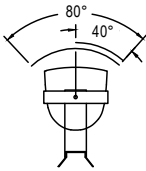

R.15COAX

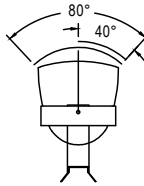

R.35COAX, R.35-3896

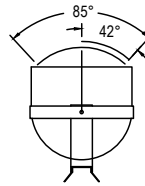

R.5, R.5MAX

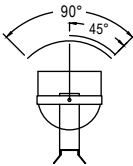

R.25

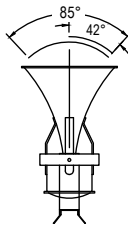

RMG-200A

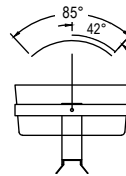

W2-218, W2-228,
W2-2W8



Installation of loudspeakers should be performed only by trained and qualified personnel. It is strongly recommended that a licensed professional structural engineer approve the mounting design.

SIDE VIEW: Downward tilt capability of single loudspeaker

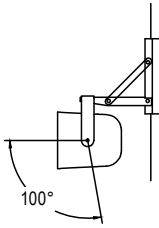

R.15COAX

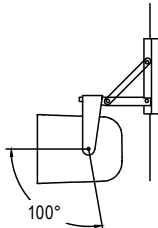

R.35COAX, R.35-3896

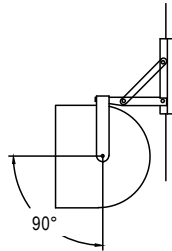

R.5, R.5MAX

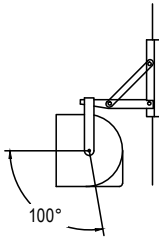

R.25

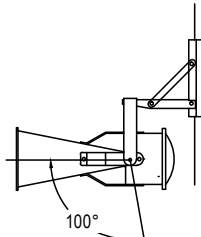

RMG-200A

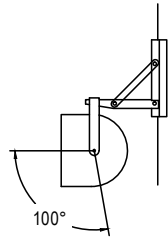

W2-218, W2-228,
W2-2W8

SIDE VIEW: Downward tilt capability of dual loudspeakers

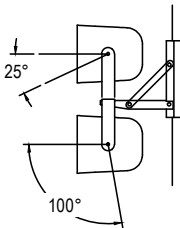

R.15COAX

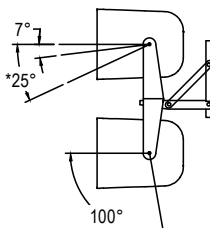

R.35COAX, R.35-3896
*REQUIRES R-FRY35 YOKE

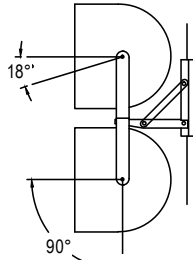

R.5, R.5MAX

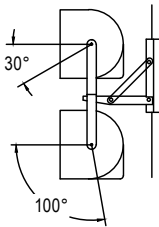

R.25

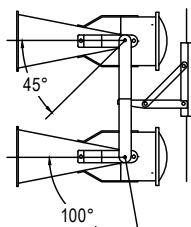

RMG-200A

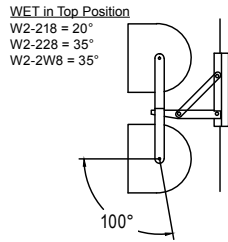

WET in Top Position

W2-218 = 20°

W2-228 = 35°

W2-2W8 = 35°

W2-218, W2-228,
W2-2W8



Community Professional Loudspeakers
333 East Fifth Street, Chester, PA 19013-4511 USA
Phone: (610) 876-3400 • Fax: (610) 874-0190
www.communitypro.com

©2013 Community Professional Loudspeakers

#113009 13SEPT2013