

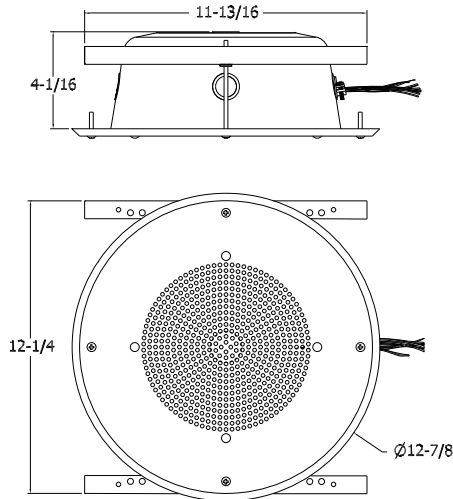

# SYSTEM 21

Hard Ceiling, Blind Mount Speaker System  
25/70V, Color Coded Leads

## INSTALLER PACKAGE LOUDSPEAKER ASSEMBLY



### GENERAL DESCRIPTION

The SYSTEM 21 is a complete loudspeaker assembly with an O.D. loudspeaker with concentric mount hard fiber HF cone, dual voltage transformer, perforated 22 gage steel baffle, 16 gage steel back box with integral mounting rails for blind-mount into hard ceiling structures up to 3 inches thick. Baffle finish: White baked epoxy hybrid.

### SYSTEM COMPONENTS

Loudspeaker	8C10PAX
Transformer	25/70V 5W- 5 tap Color coded leads (5W, 2.5W, 1.25W, 0.63W, 0.31W)
Baffle	BR8W
Enclosure	ERD8U, UL Listed-UUMW

### AUDIO SPECIFICATIONS

Average Sensitivity	92 dB-SPL 1W/1M
Loudspeaker Power Rating	20W RMS EIA 426A Standard
Calculated Maximum System Output	104 dB-SPL 5W/1M
Magnet Type, Weight	BeFe Ceramic, 10 oz.
Frequency Response	60 Hz - 17 kHz EIA 426A Standard
Nominal Coverage Angle	90° included angle -6 dB/ 2 kHz, half space
Audio Connection	Pre-cut 7" color coded leads
Electrical Access	1/2" clamp for flexible conduit, side mount

### INTENDED USE

Indoor environment  
Program Material: Paging and background music

Recommended construction sequences, installation instructions and A&E Specifications are available in various formats in the QUAM Architects' and Engineers' Resources section on the web at: [www.QuamSpeakers.com](http://www.QuamSpeakers.com)

### QUAM-NICHOLS COMPANY

234 East Marquette Road, Chicago IL 60637  
Phone: (800) NEED NOW Fax: (888) NEED NOW  
(800) 633-3669 (888) 633-3669  
E-Mail: [NeedNow@QNC.com](mailto:NeedNow@QNC.com) [www.QuamSpeakers.com](http://www.QuamSpeakers.com)

