



# VB-TILT

## VERIS 2 Series Tilting Bracket

### Tilting bracket for Community's VERIS 2 installation series loudspeakers

The VB-TILT Tilting bracket is specifically designed for use with the Community VERIS 2 Series of installation loudspeakers. It is a two-part rotational device that fastens to a yoke bracket or to other hardware, enabling precise angling of one VERIS 2 loudspeaker enclosure in relation to another. It can be used with all full-range VERIS 2 loudspeakers (models V2-6, V2-8, V2-26, V2-28, V2-12, V2-15, V2-32 and V2-35).

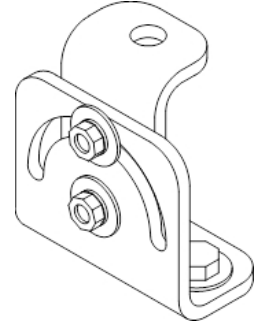

The VB-TILT is intended to be a versatile building block allowing the installer to develop and configure custom mounting solutions to suit the needs of varied applications. It can be used to hang and aim single cabinets from an overhead suspension point or to hang smaller downfill cabinets underneath main loudspeakers or loudspeaker clusters.

It is strongly recommended that the VB-TILT bracket be used in conjunction with a VERIS 2 horizontal mounting yoke or CMKIT ceiling mount kit as listed in Table 1. All VERIS 2 yokes are designed to accept the VB-TILT bracket and provide a wide range of aiming and tilting options. The VB-TILT bracket attaches directly to the yoke, permitting one loudspeaker enclosure to be angled in relation to another in two axes.

It is also possible to mount the VB-TILT bracket directly to an enclosure rigging point on large VERIS 2 models V2-12, V2-15, V2-32 and V2-35. However, caution must be taken not to place undue torque on the fitting or to exceed the single point working load limit. Each enclosure rigging point is rated at 100 lbs working load limit (WLL) with a 10:1 safety ratio.

The VB-TILT bracket is available in black or white finishes to match the color of the enclosure. Bracket parts are made of black or white powder coated steel. The hardware used for the attachment must be load-rated for the intended purpose. Also ensure that the structure you are attaching to is capable of supporting the loudspeaker and bracket assembly. This must include any torque load that may be applied to the structure as a result of the loudspeaker position and aiming angle.

The VB-TILT provides a high degree of safety for supporting the loudspeaker enclosure when used correctly. Mounting methods other than those shown in this guide should be carefully considered so that undue strain and possible failure of the mounting points does not occur.

### VB-TILT Parts List

- |                           |                               |
|---------------------------|-------------------------------|
| Rotational Bracket (1)    | M10 35mm Shoulder Eyebolt (1) |
| Suspension Bracket (1)    | M8 25mm Bolt (2)              |
| M10 30mm Bolt (2)         | M8 Flat Washer (4)            |
| M10 Flat Washer (4)       | M8 Split Lock Washer (2)      |
| M10 Split Lock Washer (2) | M8 Hex Nut (2)                |
| M10 Hex Nut (2)           |                               |

*The installer must supply all other hardware for the installation.*

### Table 1: Optional Mounting Brackets for Use with VB-TILT

It is strongly recommended to use the VB-TILT with other VERIS 2 Series mounting brackets as listed below.

Loudspeaker Model	Horizontal Mounting Yoke Part No.	Ceiling Mount Kit Part No.
V2-6	Included with Loudspeaker	CMKIT
V2-8	Included with Loudspeaker	CMKIT
V2-26	Included with Loudspeaker	CMKIT
V2-28	Included with Loudspeaker	CMKIT
V2-12	VB-Y12	CMKIT
V2-15	VB-Y15	CMKIT
V2-32	VB-Y32	CMKIT
V2-35	VB-Y35	CMKIT

**Figure 1: VB-TILT Bracket Dimensions**

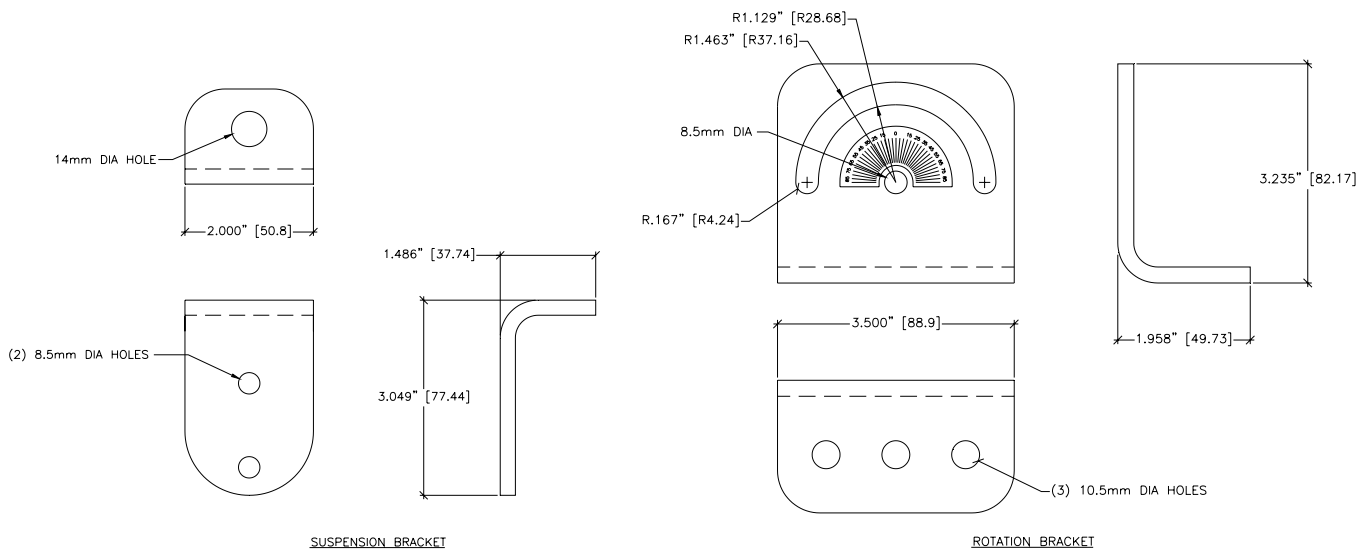

**Figure 2: VB-TILT Assembly**

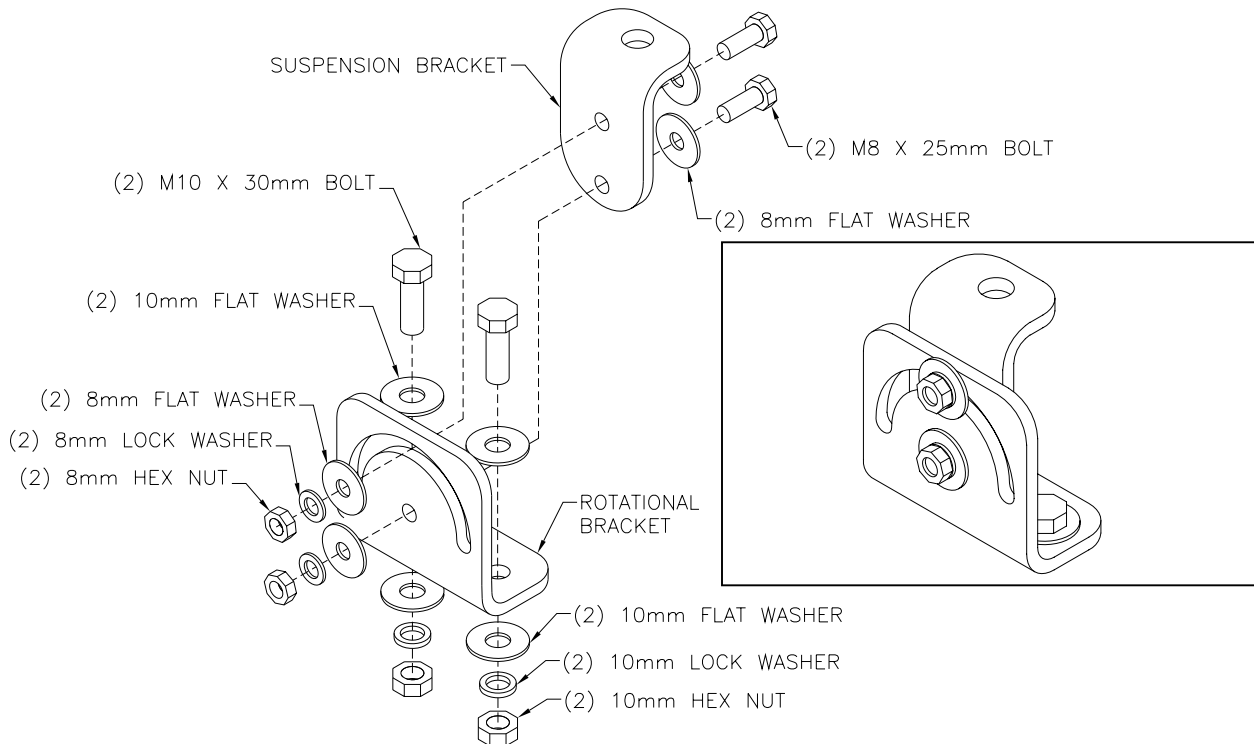

**Using the VB-TILT with the CMKIT**

For complete instructions on using the VB-TILT with the CMKIT ceiling mount kit, refer to the CMKIT instruction guide.

**Assembly Instructions – Using the VB-TILT with VERIS 2 Yokes**

1. The VB-TILT comes assembled from the Community Factory with the hardware finger-tight; there is no need to assemble most individual parts. The nuts and bolts must be tightened to their final torque settings in the specific order outlined in steps 2 and 3 below to avoid improper installation, injury, or even death.

2. Attach the Rotational Bracket to the desired VERIS 2 Yoke using the provided M10 nuts, bolts and washers. The Yoke should be placed between the bottom of the Rotational Bracket and the lower M10 flat washers. Once the Rotational Bracket is in the final desired position on the Yoke, tighten the M10 hardware to secure the bracket assembly to the Yoke.
3. After determining that the Rotational Bracket is in the correct position for the desired loudspeaker aiming (see instructions and aiming limitations below), tighten the 8mm bolts that join the Suspension Bracket to the Rotational Bracket.

### VB-TILT Application and Aiming Instructions

NOTE: *The recommended application of the VB-TILT bracket requires that the loudspeaker's center of gravity (COG) be located directly under and in alignment with the center suspension point of the Suspension Bracket (see Figure 3 below). This method of mounting is intended to minimize any torque load placed on the structural attachment point(s). The following instructions and angle adjustment ranges are provided taking into account this COG restriction.*

**Figure 3: Recommended COG Alignment**

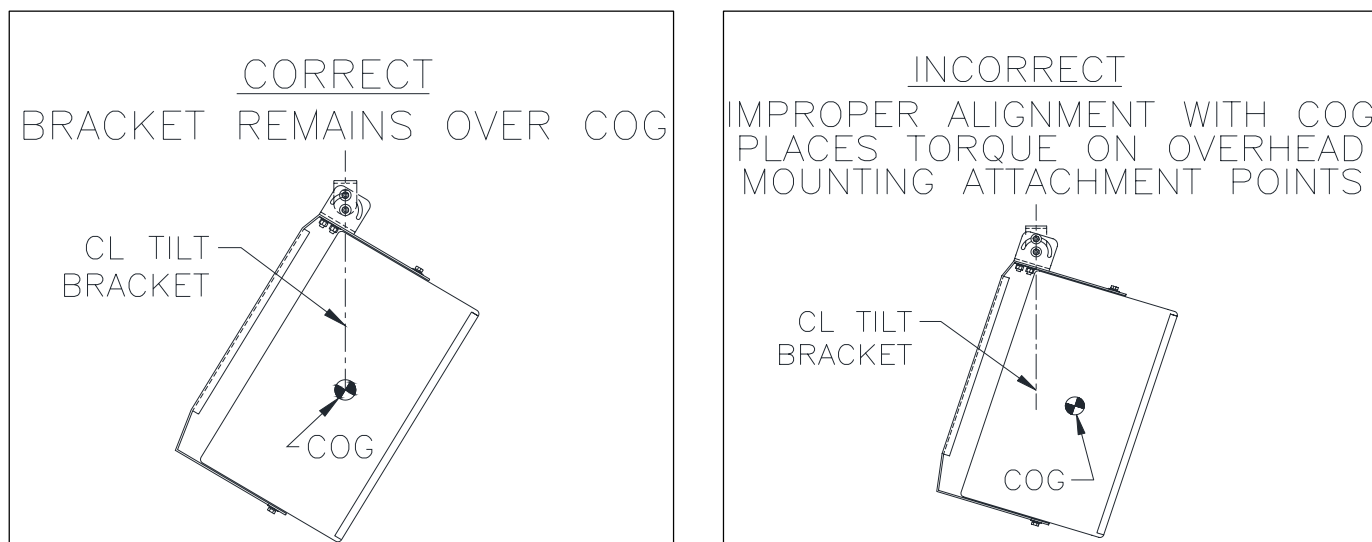

**Figure 4: VB-TILT Yoke Attachment Points**

- NOTE: *Each VERIS 2 Yoke has multiple attachment points for the VB-TILT Bracket including:*
- a.) *Two (2) holes at each end of the yoke*
  - b.) *Slots along the rear of the yoke that allow for continuous adjustment*
  - c.) *Holes near the center of the yoke that are directly over the loudspeaker COG.*

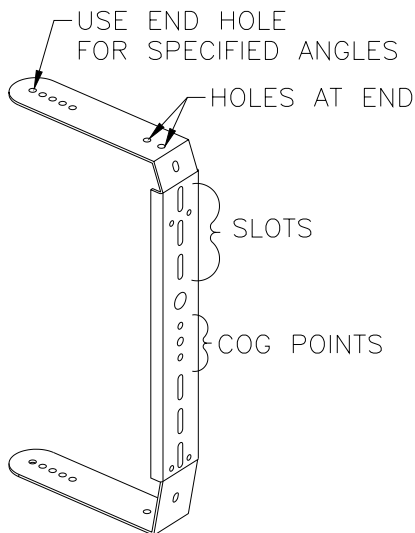

## Figure 5: VB-TILT Vertical Down-Tilt Ranges / Attachment Locations

NOTE: The following specified angles are achieved using the yoke mounting hole closest to the end of the yoke. The yoke must also be oriented with the short 20 degree bend on the rear of the yoke towards the top of the enclosure.

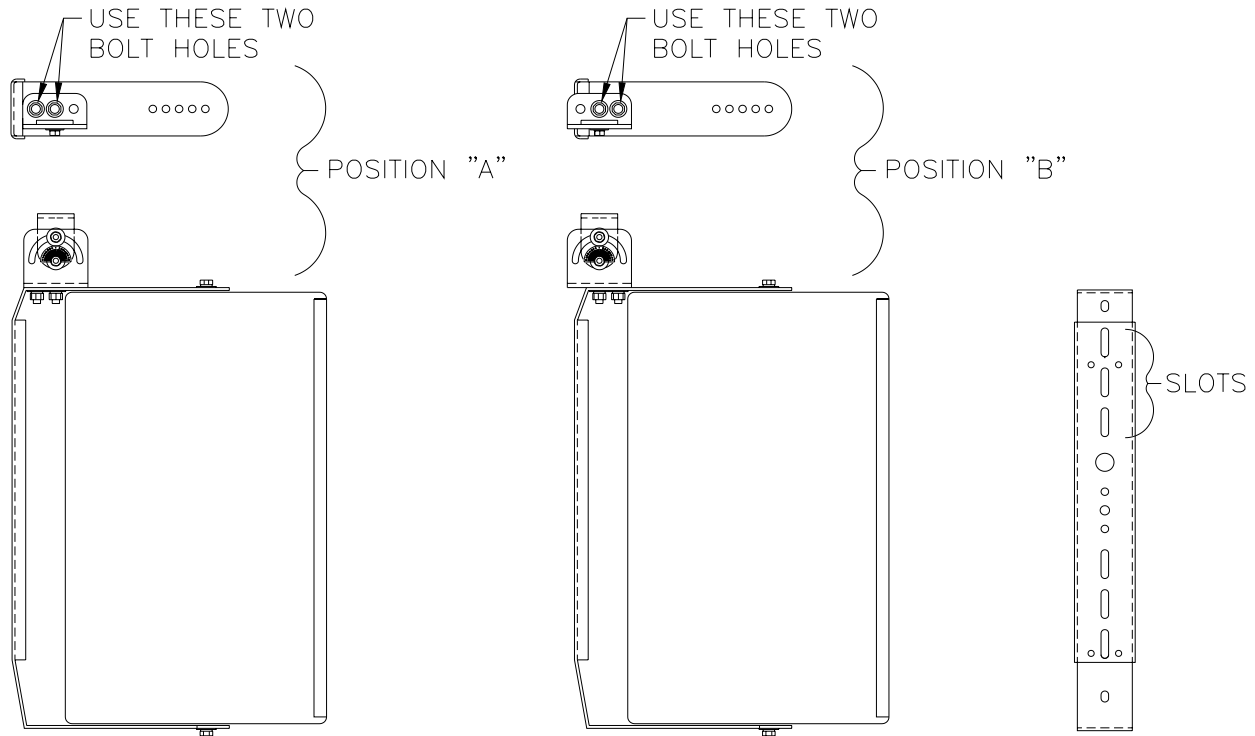

Loudspeaker Model	Vertical Tilt in Degrees		
	Position A	Position B	Rear Yoke Slots Adjustment Range
V2-6	29	34	58 – 89
V2-8	33	37	60 – 91
V2-26	22	26	45 – 87
V2-28	23	26	43 – 83
V2-12	27	30	47 – 88
V2-15	27	29	45 – 88
V2-32	24	27	43 – 89
V2-35	23	25	39 – 89

### Safety Cable



It is strongly recommended that a safety cable be attached to the loudspeaker using one of the remaining loudspeaker enclosure rigging points. A 10mm Shoulder Eyebolt is included in the kit for this purpose.

**CAUTION:** Installation of loudspeakers should only be performed by trained and qualified personnel. It is strongly recommended that a licensed and certified professional structural engineer approve the mounting design.