

# ASSEMBLY INSTRUCTIONS

Congratulations on your purchase of the DT8500 Guitar/Keyboard Throne. Please read the below instructions carefully. *We hope you enjoy your new purchase!*

## PREPARATION

Remove the following parts from the box and identify all the parts:

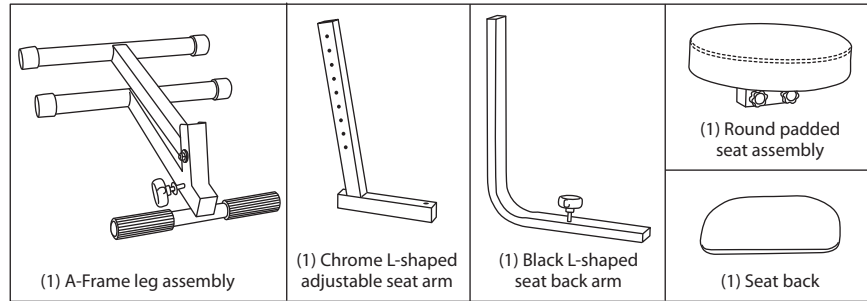

## ASSEMBLY

1. Take the A-frame leg assembly and unfold.
2. Remove the large black plastic female knob and washer from the bolt, located just below the foot rest, on the front of the A-frame leg assembly. **(Figure A)** Set aside for use in step 4.
3. Take the round padded seat assembly and loosen the two knobs on the bottom. Take the chrome L-shaped adjustable seat arm and insert the shorter end into the lower slot of the round padded seat assembly. **(Figure B)** Tighten the two knobs to secure seat.

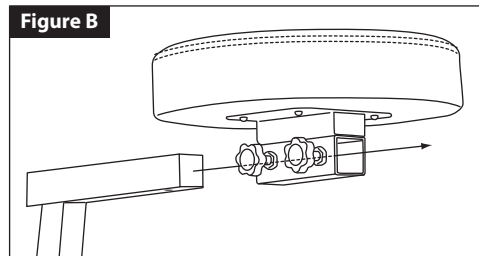
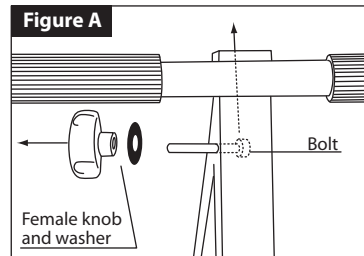

4. Insert the long end of the chrome L-shaped adjustable seat arm into the opening of the leg assembly. Take the bolt that you set aside in step 2 and insert it through the leg assembly and chrome L-shaped adjustable seat arm at desired height. **(Figure C)** Thread washer and female knob on bolt. Tighten.

5. Take the black L-shaped seat back arm and remove the male knob. Insert the short end of the L-shaped seat back into the top slot under the seat assembly from the rear of the throne. Insert the male knob through the chrome L-shaped seat arm and thread it into the hole in the black L-shaped seat back arm. Tighten. **(Figure D)**

7. Take seat back and loosen knob on back. Slide seat back onto the black L-shaped seat back arm. Tighten. **(Figure E)**

